



Sealing Solutions

SISTEMI DI TENUTA SEALING SOLUTIONS

FRIDLE GROUP	4
SOLUZIONI DI TENUTA SEALING SOLUTIONS	8
APPLICAZIONI APPLICATIONS	10
TENUTE PISTONE PISTON SEALS	12
TENUTE STELO ROD SEALS	18
ANELLI GUIDA GUIDE RINGS	22
RASCHIATORI SCRAPERS	23
TENUTE FLANGIA / STATICHE FLANGE / STATIC SEALS	27
TENUTE PER ROTAZIONE ROTATION SEALS	29
PARTNERS	33

GUARNIZIONI TORNITE MACHINED SEALS

GUARNIZIONI TORNITE MACHINED SEALS	36
MATERIALI SKF SKF MATERIALS	37
SOLUZIONI APPLICATIVE APPLICATIONS	42
TENUTE PISTONE PISTON SEALS	44
TENUTE STELO ROD SEALS	54
RASCHIATORI SCRAPERS	63
ANELLI GUIDA GUIDE RINGS	71
ANELLI DI BACK-UP BACK-UP RINGS	73
TENUTE PER ROTAZIONE ROTATION SEALS	64
TENUTE FLANGIA / STATICHE FLANGE / STATIC SEALS	81

FRIDLE GROUP. QUANDO TENERCI SIGNIFICA DARE VITA ALLA PERFETTA SINERGIA TRA SOLIDITÀ E FLESSIBILITÀ.

FRIDLE GROUP:
FOR OVER 40 YEARS
SEALING SOLUTIONS,
FLUID CONNECTORS AND
HYDRAULIC COMPONENTS..

The group, since the beginning, has been synonymous with quality, proactive advice and constant technical support, in area of application.

And it was our natural propensity to adapt, combined with a flexible approach, that allowed us to find the necessary tools to embark on a path of continuous growth, making room for more and more customers and suppliers.

But also to new partners, such as Guarnifluid and HT-Hydraulic Technology, which are now to all intents and purposes an integral and constituent part of our group.

Where this room did not exist, however, we decided to create it; as in the case of the Fridle Academy, a real knowledge hub that we chose to dedicate to sharing our specialist know-how to the benefit of all our customers.

FRIDLE GROUP:
DA OLTRE 40 ANNI
SISTEMI DI TENUTA,
FLUID CONNECTORS E
COMPONENTI OLEODINAMICI.

Il gruppo è, da sempre, sinonimo di qualità, consulenza proattiva e assistenza tecnica costante in ogni settore di applicazione.

Ed è stata proprio la nostra naturale propensione all'adattamento, unita a un approccio flessibile, a permetterci di trovare gli strumenti necessari per intraprendere un percorso di crescita continua, facendo spazio a un numero sempre maggiore di clienti e fornitori.

Ma anche a nuovi partner, come Guarnifluid e HT-Hydraulic Technology, che sono parte integrante del nostro gruppo.

Laddove questo spazio non c'era, invece, abbiamo deciso di crearlo; come nel caso della Fridle Academy, un vero e proprio hub di conoscenze che abbiamo scelto di dedicare alla condivisione del nostro know-how specialistico a favore di tutti i nostri clienti.

FRIDLE GROUP.
WHEN CARING
MEANS GIVING LIFE
TO THE PERFECT
SYNERGY
BETWEEN SOLIDITY
AND FLEXIBILITY.



NON PERDERE. QUINDI GARANTIRE.



Non si tratta solo di offrire una vasta gamma di referenze di prodotto a stock ma anche di garantire un'eccellente qualità nel servizio. Il nostro staff fornisce quotidianamente consulenza, scouting di prodotto, flessibilità e velocità di reazione in Italia e sui mercati internazionali. Con le sedi di Vicenza, Brescia, Mantova, Modena e un sistema logistico ottimizzato, organizziamo e distribuiamo gli articoli in tempi rapidi. Grazie alla nostra capacità di assistenza online e vendita e-commerce, supportata da processi logistici completamente automatizzati, arriviamo ovunque i nostri clienti abbiano bisogno del nostro intervento, consulenza o fornitura.

NOT LOSING. THEREFORE GUARANTEEING.

It's not only about offering a full range of product references in stock, but also guaranteeing excellent service quality. Our staff provides daily consulting, product scouting, flexibility and reaction speed in Italy and for international markets. With facilities in Vicenza, Brescia, Mantova and Modena and an optimised logistics system, we organise and distribute items quickly. Thanks to our online service and e-commerce capability, supported by fully automated logistical processes, we arrive wherever our customers need our intervention, advice or delivery.



I NOSTRI SERVIZI OUR SERVICES

-  **CONSULENZA E ASSISTENZA TECNICA**
CONSULTANCY AND TECHNICAL ASSISTANCE
-  **MILIONI DI PRODOTTI A MAGAZZINO**
MILLIONS OF PRODUCTS IN STOCK
-  **LOGISTICA INTEGRATA E KANBAN**
INTEGRATED LOGISTICS AND KANBAN
-  **CONTROLLO QUALITÀ IN ENTRATA E IN USCITA**
INBOUND AND OUTBOUND QUALITY CONTROL
-  **PROGETTAZIONE E PRODUZIONE A DISEGNO DI GUARNIZIONI**
DESIGN AND CUSTOMIZED SEALS PRODUCTION
-  **ETICHETTE PERSONALIZZATE E QR CODE**
CUSTOMISED LABELS AND QR CODES
-  **ORDINI WEB**
WEB ORDERS
-  **RILEVAZIONE CAMPIONI E KIT DEL CLIENTE**
ARTICLE DETECTION AND KIT ASSEMBLY
-  **ASSEMBLAGGIO E COLLAUDO TUBI E RACCORDI**
ASSEMBLY AND TESTING OF HOSES AND FITTINGS
-  **EVENTI FORMATIVI**
TRAINING EVENTS

SOLUZIONI DI TENUTA

SEALING SOLUTIONS



TENUTE IDRAULICHE HYDRAULIC SEALS

Profilo compatto per un'ottima tenuta alle alte e basse velocità, oltre che in condizioni statiche.

Compact profile for excellent sealing both at high and low speed and in static conditions.



ANELLI DI TENUTA PER ALBERI ROTANTI ROTARY SHAFT SEALS

Labbro di tenuta con molla di trazione per trattenere il fluido lubrificante ed elemento parapolvere per isolare dalle impurità esterne.

Spring loaded sealing lip to contain the lubricating fluid and wiper to isolate from external impurities.



TENUTE PER ROTAZIONE AD ELEVATE PRESTAZIONI HIGH PERFORMANCE ROTARY SEALS

Labbro di tenuta con molla di trazione per trattenere il fluido lubrificante ed elemento parapolvere per isolare dalle impurità esterne.

Spring loaded sealing lip to contain the lubricating fluid and wiper to isolate from external impurities.

GUARNIZIONI IN PTFE PTFE SEALS

Vasta gamma di profili di tenuta realizzati in PTFE per garantire elevata resistenza alle basse/alte temperature e agli agenti chimici, bassa infiammabilità e ridotto coefficiente d'attrito. Particolarmente adatto per applicazioni meccaniche, alimentari, elettriche e chimiche.

Wide range of sealing profiles built in PTFE to ensure high resistance to low/high temperatures and to chemical agents, low ignitability and reduced friction coefficient.

Very performing in mechanical, food, electrical and chemical applications.

GUARNIZIONI STATICHE STATIC SEALS

Guarnizioni utilizzate in applicazioni ove è assente il movimento tra la tenuta e la relativa superficie di accoppiamento.

Used in applications where there is no shifting between the seal and the mating surface.

O-RING

FEP O-RING

X-RING

TRICLAMP

DUALSEALS

GUARNIZIONI METALLICHE CON MATERIALI CERTIFICATI METAL SEALS AVAILABLE ALSO IN CERTIFIED MATERIALS

ANELLI E NASTRI GUIDA WEAR RINGS AND WEAR STRIPS

Elementi indispensabili nell'assorbire le sollecitazioni radiali e garantire l'affidabilità nelle applicazioni lineari.

Necessary components to absorb radial forces and to ensure durability in linear applications.

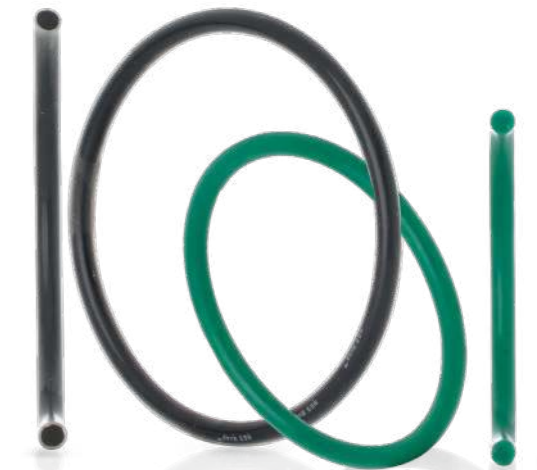

APPLICAZIONI APPLICATIONS

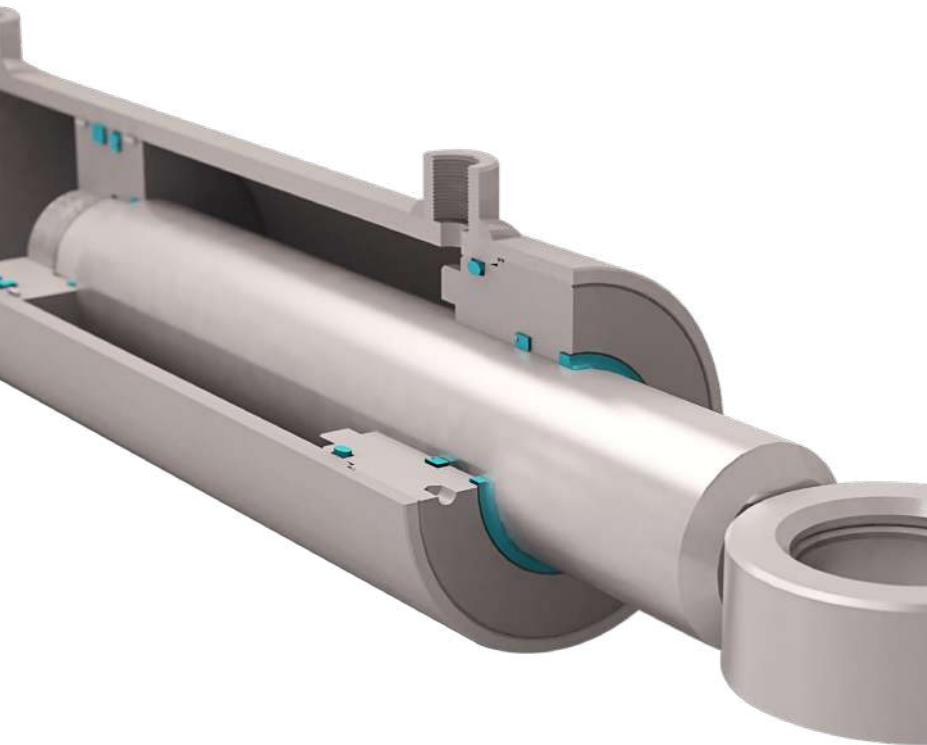

TENUTE PER CILINDRI OLEODINAMICI SEALS FOR HYDRAULIC CYLINDERS

Guarnizioni per applicazioni statiche e dinamiche in elastomero, TPU, PTFE, termoplastici tecnici (POM, PA, PE, PEEK), resine fenoliche e poliesteri. Soluzioni per cilindri speciali. Fornibili in kit.

Seals for static and dynamic applications in elastomers, TPU, PTFE, technical thermoplastics (POM, PA, PE, PEEK), phenolic resins and polyester. Solutions for special cylinders, also in kit.



TENUTE PER I SETTORI FOOD & BEVERAGE SEALS FOR FOOD & BEVERAGE INDUSTRY

Tenute per applicazioni statiche e dinamiche con certificazione FDA, CE 1935/2004, 3A. Profili standard e a disegno in materiali quali: EPDM, FKM, MVQ, FFKM, PUR, PTFE. Guarnizioni incapsulate per ottenere la massima resa nelle operazioni di sanificazione. Guarnizioni detectabili con certificazione alimentare.

Seals for static and dynamic applications with FDA, CE 1935/2004, 3A certification. Standard and custom profiles in materials such as EPDM, FKM, MVQ, FFKM, PUR, PTFE. Encapsulated gaskets to obtain the maximum performance in sanitizing operations. Detectable gaskets with food certification.

TENUTE PER IL SETTORE FARMACEUTICO & BIOMEDICALE SEALS FOR PHARMACEUTICAL & BIOMEDICAL INDUSTRY

Tenute per applicazioni statiche e dinamiche con certificazioni: USP VI nei materiali EPDM, FKM, FFKM, MVQ e PTFE. Profili standard e a disegno.

Seals for static and dynamic applications with certifications: USP VI in EPDM, FKM, FFKM, MVQ and PTFE materials. Standard and custom profiles.



TENUTE PER I SETTORI CHIMICO, OIL & GAS SEALS FOR CHEMICAL AND OIL & GAS INDUSTRIES

Guarnizioni per impiego statico e dinamico. Materiali adatti a basse e alte temperature, altissime pressioni e ad elevata resistenza chimica, che prevengono la decompressione esplosiva secondo gli standard Norsok M710, Total GS PVV 142, Nace TM 0297, MCC RED-01.









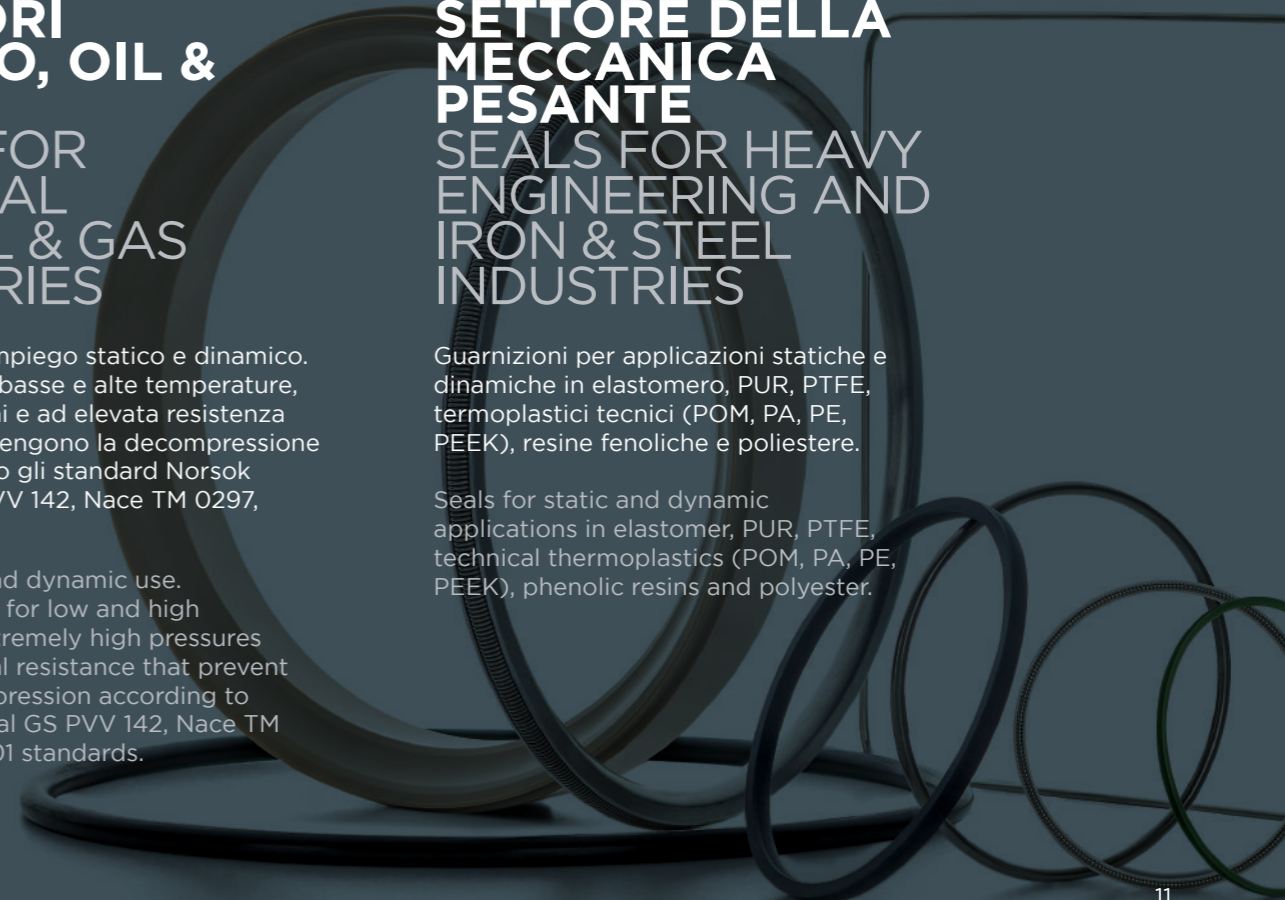



Seals for static and dynamic use. Materials suitable for low and high temperatures, extremely high pressures and high chemical resistance that prevent explosive decompression according to Norsok M710, Total GS PVV 142, Nace TM 0297, MCC RED-01 standards.

TENUTE PER IL SETTORE DELLA MECCANICA PESANTE SEALS FOR HEAVY ENGINEERING AND IRON & STEEL INDUSTRIES

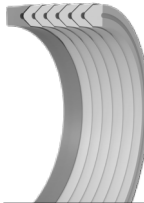
Guarnizioni per applicazioni statiche e dinamiche in elastomero, PUR, PTFE, termoplastici tecnici (POM, PA, PE, PEEK), resine fenoliche e poliesteri.

Seals for static and dynamic applications in elastomer, PUR, PTFE, technical thermoplastics (POM, PA, PE, PEEK), phenolic resins and polyester.



Tipo Type	Codice Code	Usi Use	Condizioni di esercizio Operating conditions			Materiali Materials												
			T °C MIN / MAX	S m/s MAX	P bar MAX	PUR	Gomma tela Reinforced rubber	NBR	FKM	EPDM	SIL	FFKM	Capsula FEP FEP encapsulated	PTFE	PTFE caricato Compounded PTFE	Rinforzo metallico Metallic reinforcement	MCF	
 Tenute pistone doppio effetto compatta <i>Double acting compact piston seal</i>	020DBM	 D	-35 +200	0,5	250			•	•									
 Tenute pistone doppio effetto compatta <i>Double acting compact piston seal</i>	020DPS 020DW 020DPC	 D	-35 +200	0,5	700		•		•									
 Tenute pistone doppio effetto <i>Double acting piston seal</i>	020DSM	 D	-35 +200	0,5	700		•		•									
 Tenute a pacco gomma tela <i>Cotton reinforced rubber packing seal</i>	020CH	 S	-300 +200	0,5	250		•		•									
 Tenute pistone simmetrica PUR <i>PUR symmetric piston seal</i>	042	 S	-40 +100	0,5	400		•											
 Tenute pistone asimmetrica PUR <i>PUR asymmetric piston seal</i>	043 043W	 S	-30 +100	0,5	400		•											

PUR Poliuretano
Polyurethane

NBR Gomma nitrilica
Nitrile rubber

FKM Fluoroelastomero
Fluoroelastomer

EPDM Etilene-Propilene
Ethylene-Propylene

SIL Silicene
Silicone

FFKM Perfluoroelastomero
Perfluoroelastomer

FEP Fluoropolimero
Fluoropolymer

PTFE Politetrafluoroetilene
Polytetrafluoroethylene

MCF Materiale composto
Composite material

 Statico
Static

 Alternato
Alternate













 Elicoidale
Helical

 Oscillante
Swinging

 Rotatorio
Rotary

S Singolo effetto
Single acting

D Doppio effetto
Double acting

Tipo Type	Codice Code	Usi Use	Condizioni di esercizio Operating conditions			Materiali Materials												
			T °C MIN / MAX	S m/s MAX	P bar MAX	PUR	Gomma tela Reinforced rubber	NBR	FKM	EPDM	SIL	FFKM	Capsula FEP FEP encapsulated	PTFE	PTFE caricato Compounded PTFE	Rinforzo metallico Metallic reinforcement	MCF	
 Tenute stelo/pistone + espansore <i>Cotton fabric reinforced piston and rod seal</i>	050G10	 S	-35 +200	0,5	400		•		•									
 Tenute pistone gomma tela + AE <i>Cotton fabric reinforced rubber piston seal + AE</i>	020DS	 S	-35 +200	0,5	500		•		•									
 Tenute pistone singolo effetto PTFE <i>Single acting PTFE piston seal</i>	070NPR	 D	-30 +200	15	700													•
 Tenute pistone doppio effetto PTFE <i>Double acting PTFE piston seal</i>	070NPS	 D	-30 +200	15	700													•
 Tenute pistone doppio effetto <i>Double acting piston seal</i>	070NPUK	 S	-30 +100	0,5	400		•											
 Tenute pistone doppio effetto <i>Double acting piston seal</i>	070NPU	 S	-30 +100	0,5	250		•											

PUR Poliuretano
Polyurethane

NBR Gomma nitrilica
Nitrile rubber

FKM Fluoroelastomero
Fluoroelastomer

EPDM Etilene-Propilene
Ethylene-Propylene

SIL Silicene
Silicone

FFKM Perfluoroelastomero
Perfluoroelastomer

FEP Fluoropolimero
Fluoropolymer

PTFE Politetrafluoroetilene
Polytetrafluoroethylene

MCF Materiale composto
Composite material

 Statico
Static

 Alternato
Alternate

















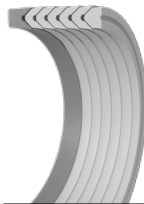

 Elicoidale
Helical

 Oscillante
Swinging

 Rotatorio
Rotary

S Singolo effetto
Single acting

D Doppio effetto
Double acting

Tipo Type	Codice Code	Usi Use	Condizioni di esercizio Operating conditions			Materiali Materials												
			T °C MIN / MAX	S m/s MAX	P bar MAX	PUR	Gomma tela Reinforced rubber	NBR	FKM	EPDM	SIL	FFKM	Capsula FEP FEP encapsulated	PTEF	PTFE caricato Compounded PTFE	Rinforzo metallico Metallic reinforcement	MCF	
 Tenute stelo e pistone gomma tela <i>Cotton reinforced rubber piston and rod seal</i>	020B	  S	-300 +200	0,5	250		•		•									
 Tenute stelo gomma tela + Al <i>Cotton fabric reinforced rubber rod seal* + IBR</i>	020BNEI	  S	-30 +200	0,5	400		•		•									
 Tenute a pacco gomma tela <i>Cotton reinforced rubber packing seal</i>	020CHG5	  S	-300 +200	0,5	400		•		•									
 Tenute stelo gomma tela <i>Cotton fabric reinforced rubber rod seal</i>	020SM	  S	-30 +200	0,5	700		•		•									
 Tenute doppio effetto stelo compatta <i>Double acting compact rod seal</i>	120GDR	  D	-30 +100	0,5	400		•											
 Tenute tipo ribassato + O-ring <i>Low type seal + O-ring</i>	040	  S	-35 +110	0,5	400		•											

PUR Poliuretano
Polyurethane

NBR Gomma nitrilica
Nitrile rubber

FKM Fluoroelastomero
Fluoroelastomer

EPDM Etilene-Propilene
Ethylene-Propylene

SIL Silicene
Silicone

FFKM Perfluoroelastomero
Perfluoroelastomer

FEP Fluoropolimero
Fluoropolymer

PTFE Politetrafluoroetilene
Polytetrafluoroethylene

MCF Materiale composito
Composite material

 Statico
Static

 Alternato
Alternate



















 Elicoidale
Helical

 Oscillante
Swinging

 Rotatorio
Rotary

S Singolo effetto
Single acting

D Doppio effetto
Double acting

Tipo Type	Codice Code	Usi Use	Condizioni di esercizio Operating conditions			Materiali Materials												
			T °C MIN / MAX	S m/s MAX	P bar MAX	PUR	Gomma tela Reinforced rubber	NBR	FKM	EPDM	SIL	FFKM	Capsula FEP FEP encapsulated	PTEF	PTFE caricato Compounded PTFE	Rinforzo metallico Metallic reinforcement	MCF	
 Tenute stelo singolo effetto con buffer <i>Single acting rod seal with buffer</i>	040I	  S	-35 +110	1	400		•											
 Tenute stelo simmetrica PUR <i>PUR symmetric rod seal</i>	041	  S	-40 +100	0,5	400		•											
 Tenute stelo asimmetrica PUR <i>PUR asymmetric rod seal</i>	040L 040LX 040LI	  S	-40 +100	0,5	400		•											
 Tenute stelo simmetrica PUR <i>PUR symmetric rod seal</i>	040 LHI	  S	-40 +100	0,5	400		•											
 Tenute stelo simmetrica PUR <i>PUR symmetric rod seal</i>	030 LRC	  S	-40 +100	0,5	400		•								•	•		
 Tenute stelo simmetrica PUR <i>PUR symmetric rod seal</i>	030 RC	  S	-40 +100	0,5	400										•	•		

PUR Poliuretano
Polyurethane

NBR Gomma nitrilica
Nitrile rubber

FKM Fluoroelastomero
Fluoroelastomer

EPDM Etilene-Propilene
Ethylene-Propylene

SIL Silicene
Silicone

FFKM Perfluoroelastomero
Perfluoroelastomer

FEP Fluoropolimero
Fluoropolymer

PTFE Politetrafluoroetilene
Polytetrafluoroethylene

MCF Materiale composito
Composite material

 Statico
Static

 Alternato
Alternate

 Elicoidale
Helical

 Oscillante
Swinging

 Rotatorio
Rotary

S Singolo effetto
Single acting

D Doppio effetto
Double acting



SKF SEALS DISTRIBUTOR

Out of the Fridle experience we have established a new company division that is specialised in consulting, design and production of custom turned gaskets. Thanks to the SKF technology we can guarantee the highest performance sealing solution for any sector of application. We are able to machine elastomeric and thermoplastic materials with an outside diameter of up to 600 mm, guaranteeing a high quality and efficient service by offering each customer endless design and sealing solutions.

Dall'esperienza di Fridle è nata una nuova divisione aziendale specializzata nella consulenza, progettazione e produzione di guarnizioni tornite su misura. Grazie alla tecnologia SKF possiamo garantire la soluzione di tenuta più performante in qualsiasi settore di applicazione. Possiamo lavorare materiali elastomerici e termoplastici fino a un diametro esterno di 600 mm, garantendo un servizio di grande qualità ed efficienza offrendo a ogni cliente infinite soluzioni di design e di tenuta.



**PROGETTAZIONE E PRODUZIONE
A DISEGNO DI GUARNIZIONI**
DESIGN AND CUSTOMIZED SEALS PRODUCTION



MATERIALI CERTIFICATI
CERTIFIED MATERIALS



VELOCITÀ DI ESECUZIONE
FAST SERVICE



CONTROLLO QUALITÀ IN ENTRATA E IN USCITA
INBOUND AND OUTBOUND QUALITY CONTROL



EVENTI FORMATIVI
TRAINING EVENTS



GUARNIZIONI TORNITE



Lo sviluppo di nuove applicazioni di tenuta rende fondamentale la scelta di materiali sempre più performanti. Le soluzioni di tenuta devono affrontare velocità, pressioni e temperature sempre maggiori immerse in fluidi scarsamente lubrificanti. La compatibilità chimica dei materiali risulta una variabile importante da considerare, soprattutto con fluidi HFA, HFB o i moderni oli biodegradabili. In un contesto in continua evoluzione, Fridle Group propone una gamma di oltre 15 materiali suddivisi tra: elastomeri, poliuretani e termoplastici in grado di soddisfare le applicazioni più critiche. Le macchine utensili di concezione SKF, utilizzate da Fridle Group, permettono di lavorare materiali elastomerici e termoplastici fino a un diametro esterno di 600 mm. I profili delle guarnizioni prodotte da lavorazione meccanica possono essere sia standard sia speciali.

In an ever-evolving context, Fridle Group offers a range of 15 materials, divided between elastomers, polyurethans and thermoplastic, capable to meet the requirements of the most critical applications. The SKF machines operated by Fridle Group, can lathe elastomeric and thermoplastic materials with an outer diameter up to 600 mm. The machined sealing profiles can be standard or customized.

MACHINED SEALS

Selecting the most performing materials is critical in the development of new sealing solutions. Seals must face very demanding conditions of speed, pressure and temperature and frequently in contact with poor lubricating materials. The materials chemical compatibility is very important, especially with HFA, HFB fluids and with biodegradable oils.



I MATERIALI SKF SKF MATERIALS

I materiali elastomerici, estremamente flessibili, si adattano a qualsiasi superficie con il minimo sforzo. Grazie alla loro struttura hanno elevata elasticità e spesso offrono un ridotto compression set. Gli elastomeri termoplastici, più comunemente conosciuti come poliuretani, vantano le caratteristiche degli elastomeri ma con elevata durezza e resistenza all'usura. I materiali termoplastici sono più duri e rigidi, vantano elevate caratteristiche meccaniche. La nostra esperienza di oltre 40 anni ci permette di guidare il cliente nella scelta della soluzione di tenuta su misura per le proprie necessità, realizzata con il profilo ed il materiale che meglio si adattano all'applicazione, contribuendo al miglioramento continuo delle performance del prodotto finito.

Elastomers are extremely flexible materials and can easily adjust to any surface. Thanks to their structure, they have a high elasticity and resilience and usually offer a good compression set. Thermoplastic elastomers, better known as polyurethanes, demonstrate the same properties of elastomers but they are harder and more wear resistant. Thermoplastic materials are essentially harder and more rigid, they possess higher mechanical characteristics. Our expertise allows us to guide the customer in choosing the correct sealing solutions to meet all requirements, produced with the design and the material that best suit the application, constantly contributing to the improvement of the finished product.

SKF ECOPUR

Poliuretano (TPU) con ottima resistenza all'abrasione e basso compression set. Può essere utilizzato con olio minerale in applicazioni fino a 400 bar.

PROPRIETÀ SPECIFICA: RESISTENZA ALL'USURAPROPRIETÀ ALL'USURA.

Thermoplastic polyurethane with an excellent resistance to abrasion and low compression set. It can be used in mineral oil and in applications up to 400 bar.

MAIN FEATURE: WEAR RESISTANCE.

SKF S-ECOPUR

Poliuretano (TPU) autolubrificante che permette di ridurre attrito ed usura. Può essere utilizzato in applicazioni con acqua o pneumatiche.

PROPRIETÀ SPECIFICA: AUTOLUBRIFICAZIONE.

Self-lubricated thermoplastic polyurethane optimized to reduce friction and improve wear resistance. It is suitable for most critical applications in water hydraulics and in non-lubricated pneumatics.

MAIN FEATURE: SELF-LUBRICATION.

SKF H-ECOPUR

Poliuretano (TPU) resistente all'idrolisi, ottime prestazioni meccaniche e resistenza all'abrasione. Utilizzabile in acqua fino a 90°C. È particolarmente adatto ad applicazioni in ambito alimentare e marino.

PROPRIETÀ SPECIFICA: RESISTENZA ALL'IDROLISI.

Hydrolysis resistant thermoplastic polyurethane, with great mechanical properties. It can be used in water up to 90°C; it is recommended for use in food and marine applications.

MAIN FEATURE: HYDROLYSIS RESISTANCE.

SKF T-ECOPUR

Poliuretano (TPU) per applicazioni a basse temperature, garantisce le medesime proprietà dell'Ecopur in applicazioni fino a -50°C.

PROPRIETÀ SPECIFICA: RESISTENZA ALLE BASSE TEMPERATURE.

Thermoplastic polyurethane for low temperature applications. It guarantees the same properties of Ecopur in applications up to -50°C.

MAIN FEATURE: WEAR RESISTANCE.

SKF ECOPUR

Poliuretano (TPU) con ottima resistenza all'abrasione e basso compression set. Può essere utilizzato con olio minerale in applicazioni fino a 400 bar.

PROPRIETÀ SPECIFICA: RESISTENZA ALL'USURAPROPRIETÀ ALL'USURA.

Thermoplastic polyurethane with an excellent resistance to abrasion and low compression set. It can be used in mineral oil and in applications up to 400 bar.

MAIN FEATURE: LOW TEMPERATURES RESISTANCE.

SKF ECORUBBER-1

Materiale elastomerico NBR con buona resistenza agli oli minerali, fluidi HFA, HFB e HFC.

PROPRIETÀ SPECIFICA: VERSATILITÀ D'IMPIEGO.

NBR based elastomer with good resistance to mineral oils and HFA, HFB and HFC pressure fluids.

MAIN FEATURE: VERSATILITY.

SKF ECORUBBER-2

Materiale elastomerico FKM con ottima resistenza al calore, all'invecchiamento e agli agenti chimici.

PROPRIETÀ SPECIFICA: COMPATIBILITÀ CHIMICA.

FKM based elastomeric material with great resistance to heat, aging and chemical agents.

MAIN FEATURE: CHEMICAL COMPATIBILITY.

F10-50

Materiale termoplastico PTFE + Bronzo con elevate prestazioni di resistenza alla compressione, scorrevolezza e conduttività termica.

PROPRIETÀ SPECIFICA: VERSATILITÀ NEGLI IMPIEGHI.

Elastomeric material, PTFE loaded with bronze. This material offers outstanding of compression resistance, gliding and thermal conductivity.

MAIN FEATURE: VERSATILITY.

F10-148

Materiale termoplastico PTFE + fibre minerali e lubrificanti con elevata resistenza meccanica rigidità e durezza.

PROPRIETÀ SPECIFICA: RESISTENZA MECCANICA.

Thermoplastic PTFE loaded with mineral fibers and lubricants with high mechanical resistance, rigidity and hardness.

MAIN FEATURE: MECHANICAL RESISTANCE.

F10-28

Materiale termoplastico PTFE + fibre polimeriche con eccellenti prestazioni meccaniche e di resistenza all'usura, consigliato anche per applicazioni alimentari.

PROPRIETÀ SPECIFICA: RESISTENZA ALL'USURAPROPRIETÀ ALL'USURA.

Thermoplastic material, PTFE loaded with polymeric fibers. It offers outstanding mechanical performances and excellent wear resistance. Recommended for food applications.

MAIN FEATURE: WEAR RESISTANCE.

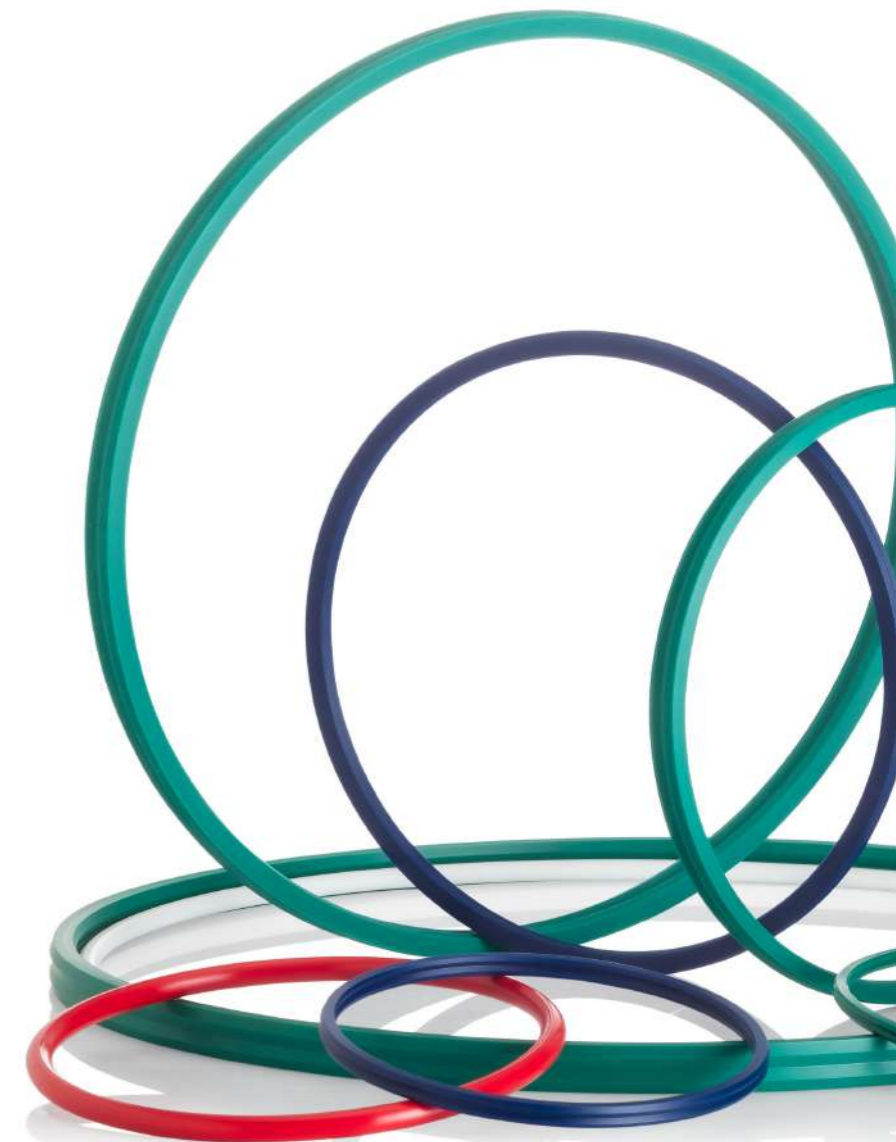

SKF ECOPAEEK

Polimero PEEK ad elevata durezza e resistenza alla trazione, mantiene le proprie caratteristiche meccaniche anche ad elevate temperature.

PROPRIETÀ SPECIFICA: DUREZZA.

PEEK polymer with high tensile strength and stiffness. It maintains its mechanical properties also at high temperatures

MAIN FEATURE: HARDNESS.

SKF X-ECOPUR H

Poliuretano (TPU) ad elevata durezza che garantisce le performance meccaniche di SKF X-Ecopur in applicazioni con fluidi a base acquosa, grazie alle proprietà di resistenza all'idrolisi.

PROPRIETÀ SPECIFICA: RESISTENZA ALL'IDROLISI E DUREZZA.

Extremely hard polyurethane which guarantees the mechanical performances of SKF X-Ecopur in water-based fluids thanks to its outstanding hydrolysis resistance

MAIN FEATURE: HYDROLYSIS RESISTANCE AND HARDNESS.

SKF X-ECOPUR

Poliuretano (TPU) ad elevata durezza, combina ottime proprietà di riduzione dell'attrito e resistenza all'usura alla resistenza ad elevate pressioni. Questo materiale può essere utilizzato in applicazioni con elevati gap radiali migliorando le prestazioni di un TPU standard o di un materiale termoplastico.

PROPRIETÀ SPECIFICA: RESISTENZA ALL'USURA E DUREZZA.

Hard grade thermoplastic polyurethane, it provides outstanding friction reduction and wear resistance as well as pressure resistance.

This material is suitable for applications with larger clearances, improving the performances of standard TPUs and thermoplastic materials.

MAIN FEATURE: WEAR RESISTANCE.

SKF X-ECOPUR S

Poliuretano (TPU) ad elevata durezza che unisce alle caratteristiche di resistenza all'estrusione degli agenti lubrificanti che riducono sensibilmente l'attrito ed ottimizzano le prestazioni in applicazioni a secco.

PROPRIETÀ SPECIFICA: AUTOLUBRIFICAZIONE E DUREZZA.

Extremely hard polyurethane which combines a better extrusion resistance to lubricating agents reducing considerably friction and optimizing the performances under poor lubricated conditions.

MAIN FEATURE: SELF-LUBRICATION AND HARDNESS.

Tabella dei materiali SKF / SKF materials chart

Materiali Materials	Colore Colour	Durezza Hardness Shore A/D	Temperatura di esercizio Operating temperature		Resistenza Resistance							
			MIN	MAX	Olio minerale Mineral oil based		Fluidi HFA-E HFA fluids		Acqua Water			
					RT	60°C	RT	60°C	RT	60°C		
Elastomeri, poliuretani <i>Elastomers, polyurethanes</i>												
ECOPUR	Elastomero poliuretano termoplastico (TPU) <i>Polyurethane (TPU)</i>	●	95/48	-30	110	+	+	0	-	+	-	
ECOPUR LD	Elastomero poliuretano prodotto per colata (CPU) <i>Cast polyurethane (CPU)</i>	●	95/48	-35	110	+	+	0	-	+	-	
G-ECOPUR	Elastomero poliuretano prodotto per colata (CPU) <i>Cast polyurethane (CPU)</i>	●	95/47	-30	110	+	+	+	+0	+	0	
H-ECOPUR	Elastomero poliuretano termoplastico (TPU) <i>Polyurethane (TPU)</i>	●	95/48	-20	110	+	+	+	+	+	+	
S-ECOPUR	Elastomero poliuretano termoplastico (TPU) <i>Polyurethane (TPU)</i>	●	95/48	-20	110	+	+	+	+	+	+	
T-ECOPUR	Elastomero poliuretano termoplastico (TPU) <i>Polyurethane (TPU)</i>	●	95/48	-50	110	+	+	0	-	+	-	
X-ECOPUR	Poliuretano termoplastico ad elevata durezza (TPU) <i>Hard grade polyurethane (TPU)</i>	●	97/57	-30	110	+	+	0	-	+	-	
X-ECOPUR H	Poliuretano termoplastico ad elevata durezza (TPU) <i>Hard grade polyurethane (TPU)</i>	●	97/60	-20	110	+	+	+	+	+	+	
X-ECOPUR S	Poliuretano termoplastico ad elevata durezza (TPU) <i>Hard grade polyurethane (TPU)</i>	●	96/58	-20	110	+	+	+	+	+	+	
Elastomeri, gomme <i>Elastomers, rubbers</i>					MIN	MAX	RT	60°C	RT	60°C	RT	60°C
SKF ECOFLAS	Elastomero a base tetrafluoroetilene-propilene (TFE/P) <i>Tetrafluoroethylene propylene rubber (TFE/P)</i>	●	83 / -	-10	200	+	+	+	+	+	+	
SKF ECORUBBER-H	NBR idrogenato (H-NBR) <i>Hydrogenated NBR (H-NBR)</i>	●	85 / -	-25	150	+	+	+	+	+	+	
SKF ECORUBBER-1	Elastomero a base acrilnitril-butadiene (NBR) <i>Acrylonitrile butadiene rubber (NBR)</i>	●	85 / -	-30	100	+	+	+	+	+	+	
SKF ECORUBBER-2	Elastomero fluorurato (FKM) <i>Fluorocarbonate rubber (FKM)</i>	●	85 / -	-20	200	+	+	+	0	+	+	
SKF ECORUBBER-3	Elastomero a base etilene-propilene-diene (EPDM) <i>Ethylene propylene diene rubber (EPDM)</i>	●	85 / -	-50	150	-	-	-	-	-	-	
SKF ECOSIL	Elastomero a base siliconi metil-vinilici (MVQ) <i>Silicone rubber (MVQ)</i>	●	85 / -	-60	100	+0	+0	0	0	+0	+0	
Elastomeri certificati <i>FDA and CE 1935 certified elastomers</i>					MIN	MAX	RT	60°C	RT	60°C	RT	60°C
H-ECOPUR	Elastomero poliuretano termoplastico (TPU) <i>Polyurethane (TPU)</i>	●	95 / 48	-20	110	+	+	+	+	+	+	
SKF ECORUBBER-3	Elastomero a base etilene-propilene-diene (EPDM) <i>Ethylene propylene diene rubber (EPDM)</i>	●	85 / -	-50	150	-	-	-	-	-	-	
Termoplastiche <i>Thermoplastics</i>					MIN	MAX	RT	60°C	RT	60°C	RT	60°C
SKF ECOFLON 1	Politetrafluoroetilene (PTFE) <i>Tetrafluoroethylene propylene rubber (TFE/P)</i>	●	- / 57	-200	260	+	+	+	+	+	+	
SKF ECOFLON 2	PTFE + 15% fibre vetro + 5% MoS ₂ <i>Polytetrafluoroethylene + 15% glass + 5% MoS₂</i>	●	- / 62	-200	260	+	+	+	+	+	+	
SKF ECOFLON 3	PTFE +40% bronzo <i>Polytetrafluoroethylene +40% bronze</i>	●	- / 65	-200	260	+	+	+	+	+	+	
SKF ECOFLON 4	PTFE +25% carbonio <i>Polytetrafluoroethylene +25% carbon</i>	●	- / 65	-200	260	+	+	+	+	+	+	
SKF ECOMID	Poliammide (PA) <i>Polyamide (PA)</i>	●	- / 77	-40	110	+	+	+	+	0	0	
SKF ECOPAEEK	Polietereterchetone (PEEK) <i>Polyaryletherketone (PEEK)</i>	●	- / 88	-100	260	+	+	+	+	+	+	
SKF ECOTAL	Copolimero poliacetico (POM) <i>Polyacetal (POM)</i>	●	- / 8	-50	100	+	+	+	+	+	+	
SKF ECOWEAR	Polietilene ad altissimo peso molecolare (UHMWPE) <i>Ultra-High Molecular Weight Polyethylene (UHMWPE)</i>	●	- / -	-200	90	+	+	+	+	+	+	

+ Resistente
Suitable

0 Dati non disponibili o resistenza limitata
Unknown data or limited resistance

- Non raccomandato
Not recommended

RT Temperatura ambiente
Room temperature (20 °C)

SOLUZIONI APPLICATIVE APPLICATIONS

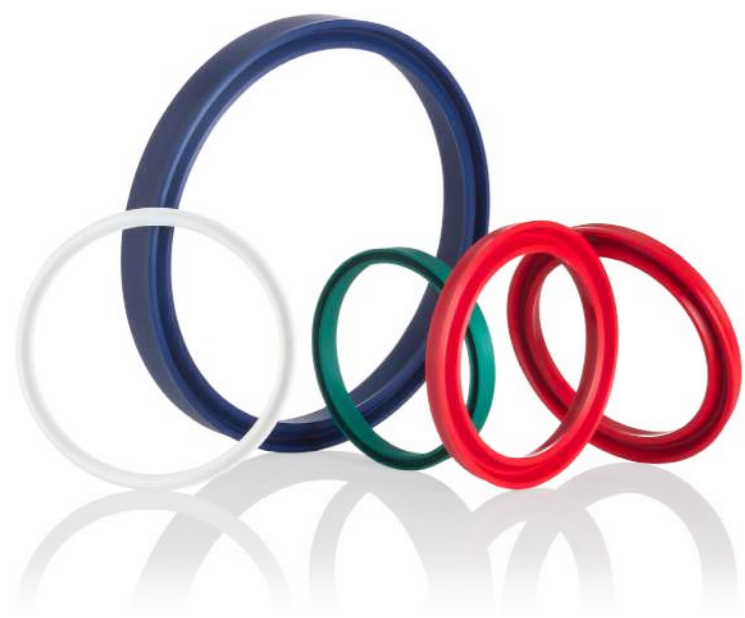

TENUTE IDRAULICHE A LABBRO HYDRAULIC LIP SEALS

Modalità produttiva: tornitura e stampaggio.
Impiego: applicazioni alternative idrauliche e pneumatiche.
Campo di applicazione: cilindri idraulici standard, presse, attuatori pneumatici.

Production method: machining and molding.
Use: hydraulic and pneumatic alternative applications.
Applications: standard hydraulic cylinders, presses, pneumatic actuators.

TENUTE IDRAULICHE IN PTFE PTFE HYDRAULIC SEALS

Modalità produttiva: tornitura e stampaggio.
Impiego: applicazioni alternative idrauliche.
Campo di applicazione : cilindri idraulici, presse, macchine movimento terra, attrezzature idrauliche.

Production method: machining and molding.
Use: hydraulic alternative applications.
Applications: hydraulic cylinders, presses, earth moving machines, hydraulic equipment.



TENUTE STATICHE STATIC SEALS

Modalità produttiva: tornitura e stampaggio.
Impiego: applicazioni idrauliche e pneumatiche.
Campo di applicazione: presse, macchine agricole, macchine movimento terra, valvole, flange e macchine utensili.

Production method: machining and molding.
Use : hydraulic and pneumatic applications.
Applications: presses, agricultural machines, earth moving machines, valves, flanges, machine tools.

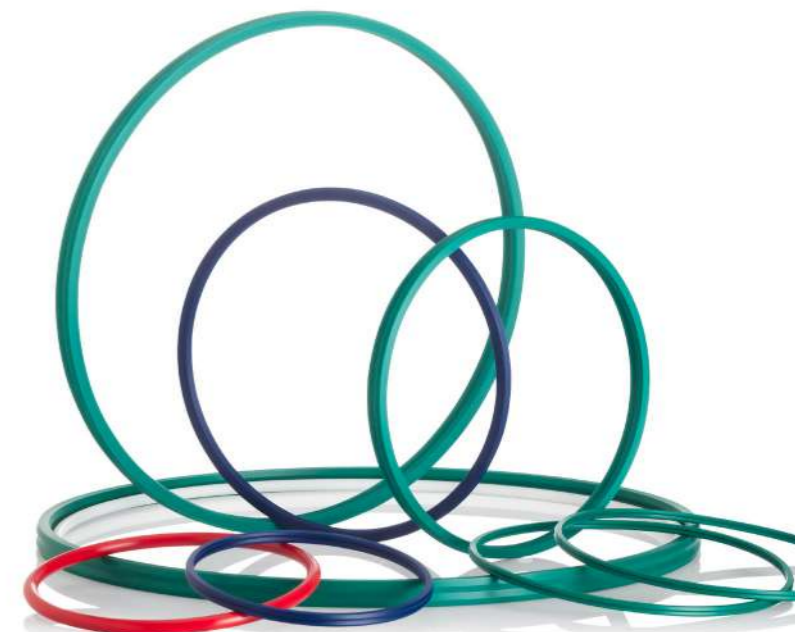

ANELLI DI TENUTA PER ALBERI ROTANTI ROTARY SHAFT SEALS

Modalità produttiva: stampaggio.
Impiego: applicazioni rotative.
Campo di applicazione: elementi rotanti, motori elettrici, riduttori, elettropompe.

Production method: molding.
Use: rotary applications.
Applications: rotating elements, electric motors, gearboxes, electric pumps.





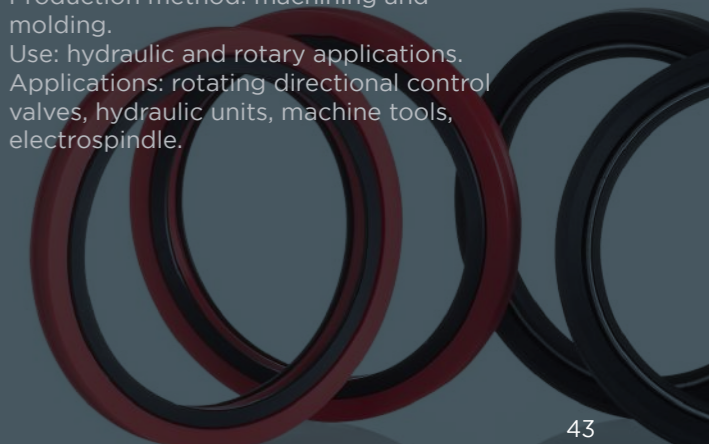

TENUTE ROTATIVE IN PTFE PTFE ROTARY SEALS

Modalità produttiva: tornitura e stampaggio.
Impiego: applicazioni idrauliche e rotanti.
Campo di applicazione : distributori rotanti, unità idrauliche, macchine utensili, elettromandri.

Production method: machining and molding.
Use: hydraulic and rotary applications.
Applications: rotating directional control valves, hydraulic units, machine tools, electrospindle.







Tipo Type	Descrizione Description Usò Use	Condizioni di esercizio Operating conditions			Materiali Materials
		T °C MIN / MAX	S m/s MAX	P bar (psi) MAX	
K01-P 	Idraulica, tenuta pistone a singolo effetto <i>Hydraulic, single acting piston seal</i>	-30 +110 -35 +110 -30 +110 -20 +110 -20 +110 -50 +110	0,5 0,5 0,5 0,5 0,7 0,5	400 (5.800) 400 (5.800) 400 (5.800) 400 (5.800) 400 (5.800) 400 (5.800)	Tenuta Seal ECOPUR ECOPUR LD G-ECOPUR H-ECOPUR S-ECOPUR T-ECOPUR
K01-PE 	Idraulica, tenuta pistone a singolo effetto <i>Hydraulic, single acting piston seal</i>	-30 +110 -35 +110 -30 +110 -20 +110 -20 +110 -50 +110	0,5 0,5 0,5 0,5 0,7 0,5	400 (5.800) 400 (5.800) 400 (5.800) 400 (5.800) 400 (5.800) 400 (5.800)	Tenuta Seal ECOPUR ECOPUR LD G-ECOPUR H-ECOPUR S-ECOPUR T-ECOPUR
K01-R 	Idraulica, tenuta pistone a singolo effetto <i>Hydraulic, single acting piston sea</i>	-10 +200 -25 +150 -30 +100 -20 +200 -50 +150 -60 +200	0,5 0,5 0,5 0,5 0,5 -	160 (2.300) 160 (2.300) 160 (2.300) 160 (2.300) 160 (2.300) -	Tenuta Seal SKF Ecoflas SKF Ecorubber-H SKF Ecorubber-1 SKF Ecorubber-2 SKF Ecorubber-3 ² SKF Ecosil ³
K01-RE 	Idraulica, tenuta pistone a singolo effetto <i>Hydraulic, single acting piston seal</i>	-10 +200 -25 +150 -30 +100 -20 +200 -50 +150 -60 +200	0,5 0,5 0,5 0,5 0,5 -	160 (2.300) 160 (2.300) 160 (2.300) 160 (2.300) 160 (2.300) -	Tenuta Seal SKF Ecoflas SKF Ecorubber-H SKF Ecorubber-1 SKF Ecorubber-2 SKF Ecorubber-3 ² SKF Ecosil ³
K02-P 	Idraulica, tenuta pistone a singolo effetto <i>Hydraulic, single acting piston seal</i>	-30 +100 -35 +100 -30 +100 -20 +100 -20 +100 -40 +100	0,5 0,5 0,5 0,5 0,7 0,5	700 (10.000) 700 (10.000) 700 (10.000) 700 (10.000) 700 (10.000) 700 (10.000)	Tenuta Seal ECOPUR ECOPUR LD G-ECOPUR H-ECOPUR S-ECOPUR T-ECOPUR Back-up Ring SKF Ecotal ¹ SKF Ecomid SKF Ecomid SKF Ecotal ¹ SKF Ecotal ¹ SKF Ecotal ¹

1. SKF Ecotal fino a Ø 260 mm, SKF Ecomid superiore a Ø 260 mm
2. Non adatto per oli minerali
3. Raccomandato solo per applicazioni statiche o quasi statiche

1. SKF Ecotal up to Ø 260 mm, SKF Ecomid above Ø 260 mm
2. Not suitable for mineral oils
3. Only recommended for static or almost static applications







Tipo Type	Descrizione Description Usò Use	Condizioni di esercizio Operating conditions			Materiali Materials
		T °C MIN / MAX	S m/s MAX	P bar (psi) MAX	
K02-PD 	Idraulica, tenuta pistone a singolo effetto <i>Hydraulic, single acting piston seal</i>	-30 +100 -35 +100 -30 +100 -20 +100 -20 +100 -40 +100	0,5 0,5 0,5 0,5 0,7 0,5	700 (10.000) 700 (10.000) 700 (10.000) 700 (10.000) 700 (10.000) 700 (10.000)	Tenuta Seal ECOPUR ECOPUR LD G-ECOPUR H-ECOPUR S-ECOPUR T-ECOPUR Back-up Ring SKF Ecotal ¹ SKF Ecomid SKF Ecomid SKF Ecotal ¹ SKF Ecotal ¹ SKF Ecotal ¹
K02-R 	Idraulica, tenuta pistone a singolo effetto <i>Hydraulic, single acting piston seal</i>	-25 +150 -25 +100 -30 +100 -20 +200 -40 +100 -50 +150 -10 +200	0,5 0,5 0,5 0,5 0,5 0,5 0,5	250 (3.600) 250 (3.600) 250 (3.600) 250 (3.600) 250 (3.600) 250 (3.600) 250 (3.600)	Tenuta Seal SKF Ecorubber-H SKF Ecorubber-H SKF Ecorubber-1 SKF Ecorubber-2 SKF Ecorubber-3 ² SKF Ecorubber-3 ² SKF Ecoflas Back-up Ring SKF Ecoflon 2 SKF Ecotal ¹ SKF Ecotal ¹ SKF Ecoflon 2 SKF Ecotal ¹ SKF Ecoflon 2 SKF Ecoflon 2 SKF Ecopeak
K02-RD 	Idraulica, tenuta pistone a singolo effetto <i>Hydraulic, single acting piston seal</i>	-25 +150 -25 +100 -30 +100 -20 +200 -40 +100 -50 +150 -10 +200	0,5 0,5 0,5 0,5 0,5 0,5 0,5	250 (3.600) 250 (3.600) 250 (3.600) 250 (3.600) 250 (3.600) 250 (3.600) 250 (3.600)	Tenuta Seal SKF Ecorubber-H SKF Ecorubber-H SKF Ecorubber-1 SKF Ecorubber-2 SKF Ecorubber-3 ² SKF Ecorubber-3 ² SKF Ecoflas Back-up Ring SKF Ecoflon 2 SKF Ecotal ¹ SKF Ecotal ¹ SKF Ecoflon 2 SKF Ecotal ¹ SKF Ecoflon 2 SKF Ecopeak
K03-P 	Idraulica, tenuta pistone a singolo effetto <i>Hydraulic, single acting piston seal</i>	-30 +100 -30 +100 -30 +100 -20 +100 -20 +100 -50 +110	0,5 0,5 0,5 0,5 0,7 0,5	400 (5.800) 400 (5.800) 400 (5.800) 400 (5.800) 400 (5.800) 400 (5.800)	Tenuta Seal ECOPUR ECOPUR LD G-ECOPUR H-ECOPUR S-ECOPUR T-ECOPUR O-Ring NBR 70 NBR 70 NBR 70 NBR 70 NBR 70 MVQ 70
K03-F 	PTFE, tenuta pistone a singolo effetto <i>PTFE, single acting piston seal</i>	-55 +200 -30 +100 -50 +150 -20 +200 -55 +200 -30 +100 -55 +90 -30 +90	1 1 1 1 1 1 0,5 0,5	200 (2.900) 200 (2.900) 400 (5.800) 400 (5.800) 400 (5.800) 400 (5.800) 200 (2.900) 200 (2.900)	Tenuta Seal SKF Ecoflon 1 SKF Ecoflon 1 SKF Ecoflon 2,3,4 SKF Ecoflon 2,3,4 SKF Ecoflon 2,3,4 SKF Ecoflon 2,3,4 SKF Ecoflon 2,3,4 SKF Ecowear 1000 SKF Ecowear 1000 O-Ring MVQ 70 NBR 70 EPDM FPM 75 MVQ 70 NBR 70 MVQ 70 NBR 70

1. SKF Ecotal fino a Ø 260 mm, SKF Ecomid superiore a Ø 260 mm
2. Non adatto per oli minerali

1. SKF Ecotal up to Ø 260 mm, SKF Ecomid above Ø 260 mm
2. Not suitable for mineral oils







Tipo Type	Descrizione Description Usò Use	Condizioni di esercizio Operating conditions			Materiali Materials		
		T °C MIN / MAX	S m/s MAX	P bar (psi) MAX			
K03-S 	PTFE, Tenuta pistone a singolo effetto <i>PTFE, single acting piston seal</i>	-200 +260	1	200 (2.900)	Tenuta Seal	Molla Spring	
		-200 +260	1	400 (5.800)	SKF Ecoflon 1	1.4310 ³	
		-200 +90	0,5	200 (2.900)	SKF Ecoflon 2,3,4	1.4310 ³	
					SKF Ecowear 1000	1.4310 ³	
K04-P 	PTFE, Tenuta pistone a singolo effetto <i>PTFE, single acting piston seal</i>	-30 +100	0,5	700 (10.000)	Tenuta Seal	Back-up Ring	O-Ring
		-30 +100	0,5	700 (10.000)	ECOPUR	SKF Ecotal ¹	NBR 70
		-30 +100	0,5	700 (10.000)	ECOPUR LD	SKF Ecomid	NBR 70
		-30 +100	0,5	700 (10.000)	G-ECOPUR	SKF Ecomid	NBR 70
		-20 +100	0,5	700 (10.000)	H-ECOPUR	SKF Ecotal ¹	NBR 70
		-20 +100	0,7	700 (10.000)	S-ECOPUR	SKF Ecotal ¹	NBR 70
-40 +100	0,5	700 (10.000)	T-ECOPUR	SKF Ecotal ¹	MVQ 70		
K04-PD 	Idraulica, tenuta pistone a singolo effetto <i>Hydraulic, single acting piston seal</i>	-30 +100	0,5	700 (10.000)	Tenuta Seal	Back-up Ring	O-Ring
		-30 +100	0,5	700 (10.000)	ECOPUR	SKF Ecotal ¹	NBR 70
		-30 +100	0,5	700 (10.000)	ECOPUR LD	SKF Ecomid	NBR 70
		-30 +100	0,5	700 (10.000)	G-ECOPUR	SKF Ecomid	NBR 70
		-20 +100	0,5	700 (10.000)	H-ECOPUR	SKF Ecotal ¹	NBR 70
		-20 +100	0,7	700 (10.000)	S-ECOPUR	SKF Ecotal ¹	NBR 70
-40 +100	0,5	700 (10.000)	T-ECOPUR	SKF Ecotal ¹	MVQ 70		
K05-P 	Pneumatico, tenuta pistone a singolo effetto <i>Pneumatic, single acting piston seal</i>	-30 +110	1	25 (360)	Tenuta Seal		
		-35 +110	1	25 (360)	ECOPUR		
		-30 +110	1	25 (360)	ECOPUR LD		
		-20 +110	1	25 (360)	G-ECOPUR		
		-20 +110	2	25 (360)	H-ECOPUR		
		-50 +110	1	25 (360)	S-ECOPUR		
				1	25 (360)	T-ECOPUR	
K05-R 	Pneumatico, tenuta pistone a singolo effetto <i>Pneumatic, single acting piston seal</i>	-10 +200	1	25 (360)	Tenuta Seal		
		-25 +150	1	25 (360)	SKF Ecoflas		
		-30 +100	1	25 (360)	SKF Ecorubber-H		
		-20 +200	1	25 (360)	SKF Ecorubber-1		
		-50 +150	1	25 (360)	SKF Ecorubber-2		
				1	25 (360)	SKF Ecorubber-3 ²	

1. SKF Ecotal fino a Ø 260 mm, SKF Ecomid superiore a Ø 260 mm
 2. Non adatto per oli minerali
 3. Raccomandato solo per applicazioni statiche o quasi statiche

1. SKF Ecotal up to Ø 260 mm, SKF Ecomid above Ø 260 mm
 2. Not suitable for mineral oils
 3. Only recommended for static or almost static applications







Tipo Type	Descrizione Description Usò Use	Condizioni di esercizio Operating conditions			Materiali Materials				
		T °C MIN / MAX	S m/s MAX	P bar (psi) MAX					
K06-P 	Idraulica, tenuta pistone a singolo effetto <i>Hydraulic, single acting piston seal</i>	-30 +110	0,5	400 (5.800)	Tenuta Seal				
		-35 +110	0,5	400 (5.800)	ECOPUR				
		-30 +110	0,5	400 (5.800)	ECOPUR LD				
		-20 +110	0,5	400 (5.800)	G-ECOPUR				
		-20 +110	0,7	400 (5.800)	H-ECOPUR				
		-50 +110	0,5	400 (5.800)	S-ECOPUR				
				0,5	400 (5.800)	T-ECOPUR			
K06-R 	Idraulica, tenuta pistone a singolo effetto <i>Hydraulic, single acting piston seal</i>	-10 +200	0,5	160 (2.300)	Tenuta Seal				
		-25 +150	0,5	160 (2.300)	SKF Ecoflas				
		-30 +100	0,5	160 (2.300)	SKF Ecorubber-H				
		-20 +200	0,5	160 (2.300)	SKF Ecorubber-1				
		-50 +150	0,5	160 (2.300)	SKF Ecorubber-2				
		-60 +200	-	-	SKF Ecorubber-3 ²				
				-	-	SKF Ecosil3			
K07-P 	Idraulica, tenuta pistone a singolo effetto <i>Hydraulic, single acting piston seal</i>	-30 +100	0,5	400 (5.800)	Tenuta Seal	O-Ring			
		-30 +100	0,5	400 (5.800)	ECOPUR	NBR 70			
		-30 +100	0,5	400 (5.800)	ECOPUR LD	NBR 70			
		-30 +100	0,5	400 (5.800)	G-ECOPUR	NBR 70			
		-20 +100	0,5	400 (5.800)	H-ECOPUR	NBR 70			
		-20 +100	0,7	400 (5.800)	S-ECOPUR	NBR 70			
-50 +100	0,5	400 (5.800)	T-ECOPUR	MVQ 70					
K07-F 	PTFE, tenuta pistone a singolo effetto <i>PTFE, single acting piston seal</i>	-30 +100	1	200 (2.900)	Tenuta Seal	O-Ring			
		-55 +200	1	200 (2.900)	SKF Ecoflon 1	NBR 70			
		-30 +100	1	400 (5.800)	SKF Ecoflon 1	MVQ 70			
		-20 +200	1	400 (5.800)	SKF Ecoflon 2,3,4	NBR 70			
		-50 +150	1	400 (5.800)	SKF Ecoflon 2,3,4	FPM 75			
		-55 +200	1	400 (5.800)	SKF Ecoflon 2,3,4	EPDM			
-30 +90	0,5	200 (2.900)	SKF Ecoflon 2,3,4	MVQ 70					
-55 +90	0,5	200 (2.900)	SKF Ecowear 1000	NBR 70					
				0,5	200 (2.900)	SKF Ecowear 1000	MVQ 70		
K08-E 	Idraulica, tenuta pistone a singolo effetto <i>Hydraulic, single acting piston seal</i>	-55 +110	5	600 (8.700)	Pattino	Glide Ring			
		-30 +100	5	600 (8.700)	G-ECOPUR 54D	MVQ 70			
		-55 +110	5	600 (8.700)	G-ECOPUR 54D	NBR 70			
		-30 +100	5	600 (8.700)	X-ECOPUR, H, S	MVQ 70			
		-20 +200	10	600 (8.700)	X-ECOPUR, H, S	NBR 70			
		-30 +100	10	600 (8.700)	SKF Ecoflon 2,3,4	FPM 75			
		-55 +90	5	400 (5.800)	SKF Ecoflon 2,3,4	NBR 70			
		-30 +90	5	400 (5.800)	SKF Ecoflon 2,3,4	NBR 70			
						5	400 (5.800)	SKF Ecowear 1000	MVQ 70
						5	400 (5.800)	SKF Ecowear 1000	NBR 70

1. Non adatto per oli minerali
 2. Raccomandato solo per applicazioni statiche o quasi statiche

1. Not suitable for mineral oils
 2. Only recommended for static or almost static applications







Tipo Type	Descrizione Description Usi Use	Condizioni di esercizio Operating conditions			Materiali Materials		
		T °C MIN / MAX	S m/s MAX	P bar (psi) MAX			
 K08-D	Idraulica, tenuta pistone a doppio effetto <i>Hydraulic, double acting piston seal</i>	-55 +110	5	600 (8.700)	G-ECOPUR 54D	O-Ring MVQ 70	
		-30 +100	5	600 (8.700)	G-ECOPUR 54D	NBR 70	
		-55 +110	5	600 (8.700)	X-ECOPUR, H, S	MVQ 70	
		-30 +100	5	600 (8.700)	X-ECOPUR, H, S	NBR 70	
		-20 +200	10	600 (8.700)	SKF Ecoflon 2,3,4	FPM 75	
		-30 +100	10	600 (8.700)	SKF Ecoflon 2,3,4	NBR 70	
		-55 +90	5	400 (5.800)	SKF Ecowear 1000	MVQ 70	
-30 +90	5	400 (5.800)	SKF Ecowear 1000	NBR 70			
 K08-P	Idraulica, tenuta pistone a doppio effetto <i>Hydraulic, double acting piston seal</i>	-30 +100	1	250 (3.600)	ECOPUR	O-Ring NBR 70	
		-30 +100	1	250 (3.600)	ECOPUR LD	NBR 70	
		-30 +100	1	250 (3.600)	G-ECOPUR	NBR 70	
		-20 +100	1	250 (3.600)	H-ECOPUR	NBR 70	
		-20 +100	1,4	250 (3.600)	S-ECOPUR	NBR 70	
		-50 +100	1	250 (3.600)	T-ECOPUR	MVQ 70	
		-50 +100	1	250 (3.600)	T-ECOPUR	MVQ 70	
 K08-ES	Idraulica, tenuta pistone a singolo effetto <i>Hydraulic, single acting piston seal</i>	-30 +100	5	600 (8.700)	G-ECOPUR 54D	SKF Ecorubber-1	
		-60 +110	5	600 (8.700)	G-ECOPUR 54D	SKF Ecosil	
		-30 +100	5	600 (8.700)	X-ECOPUR, H, S	SKF Ecorubber-1	
		-60 +100	5	600 (8.700)	X-ECOPUR, H, S	SKF Ecosil	
		-30 +100	10	600 (8.700)	SKF Ecoflon 2,3,4	SKF Ecorubber-1	
		-20 +200	10	600 (8.700)	SKF Ecoflon 2,3,4	SKF Ecorubber-2	
		-30 +90	5	400 (5.800)	SKF Ecowear 1000	SKF Ecorubber-1	
		-60 +90	5	400 (5.800)	SKF Ecowear 1000	SKF Ecosil	
 K08-DS	Idraulica, tenuta pistone a doppio effetto <i>Hydraulic, double acting piston seal</i>	-30 +100	5	600 (8.700)	G-ECOPUR 54D	SKF Ecorubber-1	
		-60 +110	5	600 (8.700)	G-ECOPUR 54D	SKF Ecosil	
		-30 +100	5	600 (8.700)	X-ECOPUR, H, S	SKF Ecorubber-1	
		-60 +100	5	600 (8.700)	X-ECOPUR, H, S	SKF Ecosil	
		-30 +100	10	600 (8.700)	SKF Ecoflon 2,3,4	SKF Ecorubber-1	
		-20 +200	10	600 (8.700)	SKF Ecoflon 2,3,4	SKF Ecorubber-2	
		-30 +90	5	400 (5.800)	SKF Ecowear 1000	SKF Ecorubber-1	
		-60 +90	5	400 (5.800)	SKF Ecowear 1000	SKF Ecosil	
 K09-N	Idraulica, tenuta pistone a doppio effetto <i>Hydraulic, double acting piston seal</i>	-30 +100	0,5	400 (5.800)	ECOPUR	Energizzante Energizer SKF Ecorubber-1	Back-up SKF Ecotal ¹
		-20 +100	0,5	400 (5.800)	H-ECOPUR	SKF Ecorubber-1	SKF Ecotal ¹
		-20 +100	0,7	400 (5.800)	S-ECOPUR	SKF Ecorubber-1	SKF Ecotal ¹
		-50 +100	0,5	400 (5.800)	T-ECOPUR	SKF Ecosil	SKF Ecotal ¹

1. SKF Ecotal fino a Ø 260 mm, SKF Ecomid superiore a Ø 260 mm

1. SKF Ecotal up to Ø 260 mm, SKF Ecomid above Ø 260 mm



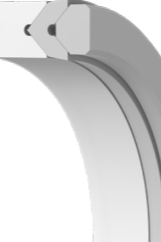



Tipo Type	Descrizione Description Usi Use	Condizioni di esercizio Operating conditions			Materiali Materials				
		T °C MIN / MAX	S m/s MAX	P bar (psi) MAX					
 K09-D	Idraulica, tenuta pistone a doppio effetto <i>Hydraulic, double acting piston seal</i>	-30 +100	0,5	400 (5.800)	Tenuta Seal ECOPUR	Energizzante Energizer SKF Ecorubber-1	Back-up SKF Ecotal ¹		
		-20 +100	0,5	400 (5.800)	H-ECOPUR	SKF Ecorubber-1	SKF Ecotal ¹		
		-20 +100	0,7	400 (5.800)	S-ECOPUR	SKF Ecorubber-1	SKF Ecotal ¹		
		-50 +100	0,5	400 (5.800)	T-ECOPUR	SKF Ecosil	SKF Ecotal ¹		
		-30 +100	0,3	1500 (21700)	ECOPUR	SKF Ecorubber-1	SKF Ecotal ¹		
		-20 +100	0,3	1500 (21700)	H-ECOPUR	SKF Ecorubber-1	SKF Ecotal ¹		
 K09-H	Idraulica, tenuta pistone a doppio effetto <i>Hydraulic, double acting piston seal</i>	-20 +100	0,4	1500 (21700)	S-ECOPUR	SKF Ecorubber-1	SKF Ecotal ¹		
		-50 +100	0,3	1500 (21700)	T-ECOPUR	SKF Ecosil	SKF Ecotal ¹		
		 K09-F	Idraulica, tenuta pistone a doppio effetto <i>Hydraulic, double acting piston seal</i>	-30 +100	1	400 (5.800)	Tenuta Seal X-ECOPUR	Energizzante Energizer SKF Ecorubber-1	Back-up Ring SKF Ecotal ¹
				-30 +100	1	400 (5.800)	X-ECOPUR, H	SKF Ecorubber-1	SKF Ecotal ¹
				-30 +100	1,2	400 (5.800)	X-ECOPUR, S	SKF Ecorubber-1	SKF Ecotal ¹
				-30 +100	1,5	400 (5.800)	SKF Ecoflon 2,3,4	SKF Ecorubber-1	SKF Ecotal ¹
-20 +200	1,5			400 (5.800)	SKF Ecoflon 2,3,4	SKF Ecorubber-2	SKF Ecopeak		
-20 +200	1,5			400 (5.800)	SKF Ecoflon 2,3,4	SKF Ecorubber-2	SKF Ecopeak		
 K01012-T	Idraulica, tenuta pistone a singolo effetto <i>Hydraulic, single acting piston seal</i>	-30 +100	0,5	500 (7.200)	K 10-A SKF Ecotal ¹	K 11-T ECOPUR	K 12-T X-ECOPUR ²		
		-35 +100	0,5	500 (7.200)	SKF Ecomid	ECOPUR LD	SKF Ecomid		
		-30 +100	0,7	500 (7.200)	SKF Ecomid	G-ECOPUR	G-ECOPUR 54D ³		
		-20 +100	0,5	500 (7.200)	SKF Ecotal ¹	H-ECOPUR	X-ECOPUR H ²		
		-20 +100	0,5	500 (7.200)	SKF Ecotal ¹	S-ECOPUR	X-ECOPUR S ²		
		-25 +150	0,5	250 (3.600)	SKF Ecoflon 2	SKF Ecorubber-H	SKF Ecoflon 2		
		-30 +100	0,5	250 (3.600)	SKF Ecoflon 2	SKF Ecorubber-1	SKF Ecoflon 2		
		-20 +200	0,5	250 (3.600)	SKF Ecoflon 2	SKF Ecorubber-2	SKF Ecoflon 2		
		-50 +150	0,5	250 (3.600)	SKF Ecoflon 2	SKF Ecorubber-3	SKF Ecoflon 2		
		 K01012-M	Idraulica, tenuta pistone a singolo effetto <i>Hydraulic, single acting piston seal</i>	-30 +100	0,5	500 (7.200)	K 10-A SKF Ecotal ¹	K 11-M ECOPUR	K 12-M X-ECOPUR ²
-35 +100	0,5			500 (7.200)	SKF Ecomid	ECOPUR LD	SKF Ecomid		
-30 +100	0,7			500 (7.200)	SKF Ecomid	G-ECOPUR	G-ECOPUR 54D ³		
-20 +100	0,5			500 (7.200)	SKF Ecotal ¹	H-ECOPUR	X-ECOPUR H ²		
-20 +100	0,5			500 (7.200)	SKF Ecotal ¹	S-ECOPUR	X-ECOPUR S ²		
-25 +150	0,5			250 (3.600)	SKF Ecoflon 2	SKF Ecorubber-H	SKF Ecoflon 2		
-30 +100	0,5			250 (3.600)	SKF Ecoflon 2	SKF Ecorubber-1	SKF Ecoflon 2		
-20 +200	0,5			250 (3.600)	SKF Ecoflon 2	SKF Ecorubber-2	SKF Ecoflon 2		
-50 +150	0,5			250 (3.600)	SKF Ecoflon 2	SKF Ecorubber-3	SKF Ecoflon 2		

1. SKF Ecotal fino a Ø 260 mm, SKF Ecomid superiore a Ø 260 mm
 2. SKF Ecotal alternativo fino a Ø 260 mm, SKF Ecomid superiore a Ø 260 mm
 3. SKF Ecomid alternativo

1. SKF Ecotal up to Ø 260 mm, SKF Ecomid above Ø 260 mm
 2. Alternative SKF Ecotal up to Ø 260 mm, SKF Ecomid above Ø 260 mm
 3. Alternative SKF Ecomid







Tipo Type	Descrizione Description Usi Use	Condizioni di esercizio Operating conditions			Materiali Materials		
		T °C MIN / MAX	S m/s MAX	P bar (psi) MAX	K 13-T	K 14-T	K 15-T
K1315-T 	Idraulica, tenuta pistone a singolo effetto <i>Hydraulic, single acting piston seal</i>	-30 +100 -30 +100 -35 +100 -30 +100 -20 +100 -20 +100 -20 +100 -20 +100 -40 +100	0,5 0,5 0,5 0,5 0,5 0,7 0,7 0,5	600 (8.700) 600 (8.700) 600 (8.700) 600 (8.700) 600 (8.700) 600 (8.700) 600 (8.700) 600 (8.700)	SKF Ecotal ¹ SKF Ecotal ¹ SKF Ecomid SKF Ecomid SKF Ecotal ¹ SKF Ecotal ¹ SKF Ecotal ¹ SKF Ecotal ¹ SKF Ecotal ¹	ECOPUR ECOPUR ECOPUR LD G-ECOPUR H-ECOPUR H-ECOPUR S-ECOPUR S-ECOPUR T-ECOPUR	X-ECOPUR SKF Ecotal ¹ SKF Ecomid SKF Ecomid X-ECOPUR H SKF Ecotal ¹ X-ECOPUR S SKF Ecotal ¹ SKF Ecotal ¹
K16-A 	Idraulica/pneumatica, tenuta pistone a singolo effetto <i>Hydraulic/pneumat, single acting piston seal</i>	-30 +110 -35 +110 -30 +110 -20 +110 -20 +110 -50 +110 -10 +200 -25 +150 -30 +100 -20 +200 -50 +150	0,5 0,5 0,5 0,5 0,7 0,5 0,5 0,5 0,5 0,5 0,5	160 (2.300) 160 (2.300) 160 (2.300) 160 (2.300) 160 (2.300) 160 (2.300) 160 (2.300) 160 (2.300) 160 (2.300) 160 (2.300) 160 (2.300)	Tenuta Seal ECOPUR ECOPUR LD G-ECOPUR H-ECOPUR S-ECOPUR T-ECOPUR SKF Ecoflas SKF Ecorubber-H SKF Ecorubber-1 SKF Ecorubber-2 SKF Ecorubber-3		
K16-B 	Idraulica/pneumatica, tenuta pistone a singolo effetto <i>Hydraulic/pneumat, single acting piston seal</i>	-30 +110 -35 +110 -30 +110 -20 +110 -20 +110 -50 +110 -10 +200 -25 +150 -30 +100 -20 +200 -50 +150	0,5 0,5 0,5 0,5 0,7 0,5 0,5 0,5 0,5 0,5 0,5	160 (2.300) 160 (2.300) 160 (2.300) 160 (2.300) 160 (2.300) 160 (2.300) 160 (2.300) 160 (2.300) 160 (2.300) 160 (2.300) 160 (2.300)	Tenuta Seal ECOPUR ECOPUR LD G-ECOPUR H-ECOPUR S-ECOPUR T-ECOPUR SKF Ecoflas SKF Ecorubber-H SKF Ecorubber-1 SKF Ecorubber-2 SKF Ecorubber-3		
K17-P 	Idraulica, tenuta pistone a doppio effetto <i>Hydraulic, double acting piston seal</i>	-30 +100 -20 +100 -20 +100 -40 +100	0,5 0,5 0,7 0,5	250 (3.600) 250 (3.600) 250 (3.600) 250 (3.600)	Tenuta Seal ECOPUR H-ECOPUR S-ECOPUR T-ECOPUR		Back-up Ring SKF Ecotal ¹ SKF Ecotal ¹ SKF Ecotal ¹ SKF Ecotal ¹
K17-R 	Idraulica, tenuta pistone a doppio effetto <i>Hydraulic, double acting piston seal</i>	-25 +150 -25 +150 -25 +100 -30 +100 -20 +200 -20 +200	0,5 0,5 0,5 0,5 0,5 0,5	250 (3.600) 250 (3.600) 250 (3.600) 250 (3.600) 250 (3.600) 250 (3.600)	Tenuta Seal SKF Ecorubber-H SKF Ecorubber-H SKF Ecorubber-H SKF Ecorubber-1 SKF Ecorubber-2 SKF Ecorubber-2		Back-up Ring SKF Ecoflon 2 SKF Ecopeak SKF Ecotal ¹ SKF Ecotal ¹ SKF Ecoflon 2 SKF Ecopeak

1. SKF Ecotal fino a Ø 260 mm, SKF Ecomid superiore a Ø 260 mm

1. SKF Ecotal up to Ø 260 mm, SKF Ecomid above Ø 260 mm







Tipo Type	Descrizione Description Usi Use	Condizioni di esercizio Operating conditions			Materiali Materials	
		T °C MIN / MAX	S m/s MAX	P bar (psi) MAX	Tenuta Seal	Molla Spring
K19-F 	PTFE, tenuta pistone a singolo effetto <i>PTFE, single acting piston seal</i>	-200 +260 -200 +260 -200 +260 -200 +260 -200 +90	15 15 15 15 15	200 (2.900) 400 (5.800) 400 (5.800) 400 (5.800) 200 (2.900)	Tenuta Seal SKF Ecoflon 1 SKF Ecoflon 2 SKF Ecoflon 3 SKF Ecoflon 4 SKF Ecowear 1000	
K20-R 	Idraulica, tenuta pistone a singolo effetto <i>Hydraulic, single acting rod seal</i>	-25 +150 -25 +150 -25 +100 -30 +100 -20 +200 -20 +200	0,5 0,5 0,5 0,5 0,5 0,5	700 (10.000) 700 (10.000) 700 (10.000) 700 (10.000) 700 (10.000) 700 (10.000)	Tenuta Seal SKF Ecorubber-H SKF Ecorubber-H SKF Ecorubber-H SKF Ecorubber-1 SKF Ecorubber-2 SKF Ecorubber-2	
K21-P 	Idraulica, tenuta pistone a singolo effetto <i>Hydraulic, single acting rod seal</i>	-30 +100 -20 +100 -20 +100 -50 +100	0,5 0,5 0,7 0,5	400 (5.800) 400 (5.800) 400 (5.800) 400 (5.800)	Tenuta Seal ECOPUR H-ECOPUR S-ECOPUR T-ECOPUR	
K22-P 	Idraulica, tenuta pistone a singolo effetto <i>Hydraulic, single acting rod seal</i>	-30 +100 -35 +100 -30 +100 -20 +100 -20 +100 -40 +100	0,5 0,5 0,5 0,5 0,7 0,5	400 (5.800) 400 (5.800) 400 (5.800) 400 (5.800) 400 (5.800) 400 (5.800)	Tenuta Seal ECOPUR ECOPUR LD G-ECOPUR H-ECOPUR S-ECOPUR T-ECOPUR	
K22-R 	Idraulica, tenuta pistone a singolo effetto <i>Hydraulic, single acting rod seal</i>	-10 +200 -25 +150 -25 +100 -30 +100 -20 +200 -50 +150 -40 +100	0,5 0,5 0,5 0,5 0,5 0,5 0,5	160 (2.300) 160 (2.300) 160 (2.300) 160 (2.300) 160 (2.300) 160 (2.300) 160 (2.300)	Tenuta Seal SKF Ecoflon SKF Ecorubber, H SKF Ecorubber, H SKF Ecorubber 4 SKF Ecorubber 2 SKF Ecorubber LD SKF Ecorubber LD	

1. SKF Ecotal fino a Ø 260 mm, SKF Ecomid superiore a Ø 260 mm
2. Non adatto per oli minerali

1. SKF Ecotal up to Ø 260 mm, SKF Ecomid above Ø 260 mm
2. Not suitable for mineral oils







Tipo Type	Descrizione Description Usi Use	Condizioni di esercizio Operating conditions			Materiali Materials
		T °C MIN / MAX	S m/s MAX	P bar (psi) MAX	
S01-P 	Idraulica, tenuta stelo a singolo effetto <i>Hydraulic, single acting rod seal</i>	-30 +110 -35 +110 -30 +110 -20 +110 -20 +110 -50 +110	0,5 0,5 0,5 0,5 0,7 0,5	400 (5.800) 400 (5.800) 400 (5.800) 400 (5.800) 400 (5.800) 400 (5.800)	Tenuta Seal ECOPUR ECOPUR LD G-ECOPUR H-ECOPUR S-ECOPUR T-ECOPUR
S01-R 	Idraulica, tenuta stelo a singolo effetto <i>Hydraulic, single acting rod seal</i>	-10 +200 -25 +150 -30 +100 -20 +200 -50 +150 -60 +200	0,5 0,5 0,5 0,5 0,5 -	160 (2.300) 160 (2.300) 160 (2.300) 160 (2.300) 160 (2.300) -	Tenuta Seal SKF ECOFLAS SKF ECORUBBER-H SKF ECORUBBER-1 SKF ECORUBBER-2 SKF ECORUBBER-3 ² SKF ECOSIL ³
S02-P 	Idraulica, tenuta stelo a singolo effetto <i>Hydraulic, single acting rod seal</i>	-30 +100 -35 +100 -30 +100 -20 +100 -20 +100 -40 +100	0,5 0,5 0,5 0,5 0,7 0,5	700 (10.000) 700 (10.000) 700 (10.000) 700 (10.000) 700 (10.000) 700 (10.000)	Tenuta Seal ECOPUR ECOPUR LD G-ECOPUR H-ECOPUR S-ECOPUR T-ECOPUR Back-up Ring SKF Ecotal ¹ SKF Ecomid SKF Ecomid SKF Ecotal ¹ SKF Ecotal ¹ SKF Ecotal ¹
S02-PD 	Idraulica, tenuta stelo a singolo effetto <i>Hydraulic, single acting rod seal</i>	-30 +100 -35 +100 -30 +100 -20 +100 -20 +100 -40 +100	0,5 0,5 0,5 0,5 0,7 0,5	400 (5.800) 400 (5.800) 400 (5.800) 400 (5.800) 400 (5.800) 400 (5.800)	Tenuta Seal ECOPUR ECOPUR LD G-ECOPUR H-ECOPUR S-ECOPUR T-ECOPUR Back-up Ring SKF Ecotal ¹ SKF Ecomid SKF Ecomid SKF Ecotal ¹ SKF Ecotal ¹ SKF Ecotal ¹
S02-R 	Idraulica, tenuta stelo a singolo effetto <i>Hydraulic, single acting rod seal</i>	-10 +200 -25 +150 -25 +100 -30 +100 -20 +200 -50 +150 -40 +100	0,5 0,5 0,5 0,5 0,5 0,5 0,5	250 (3.600) 250 (3.600) 250 (3.600) 250 (3.600) 250 (3.600) 250 (3.600) 250 (3.600)	Tenuta Seal SKF Ecoflas SKF Ecorubber-H SKF Ecorubber-H SKF Ecorubber-1 SKF Ecorubber-2 SKF Ecorubber-3 ² SKF Ecorubber-3 ² Back-up Ring SKF Ecopeak SKF Ecoflon 2 SKF Ecotal ¹ SKF Ecotal ¹ SKF Ecoflon 2 SKF Ecoflon 2 SKF Ecotal ¹

1. SKF Ecotal fino a Ø 260 mm, SKF Ecomid superiore a Ø 260 mm
2. Non adatto per oli minerali
3. Raccomandato solo per applicazioni statiche o quasi statiche





1. SKF Ecotal up to Ø 260 mm, SKF Ecomid above Ø 260 mm
2. Not suitable for mineral oils
3. Only recommended for static or almost static applications



Tipo Type	Descrizione Description Usi Use	Condizioni di esercizio Operating conditions			Materiali Materials	
		T °C MIN / MAX	S m/s MAX	P bar (psi) MAX	Tenuta Seal	Back-up Ring
S02-RD 	Idraulica, tenuta pistone a singolo effetto <i>Hydraulic, single acting rod seal</i>	-10 +200 -25 +150 -25 +100 -30 +100 -20 +200 -50 +150 -40 +100	0,5 0,5 0,5 0,5 0,5 0,5 0,5	250 (3.600) 250 (3.600) 250 (3.600) 250 (3.600) 250 (3.600) 250 (3.600) 250 (3.600)	Tenuta Seal SKF Ecoflas SKF Ecorubber-H SKF Ecorubber-H SKF Ecorubber-1 SKF Ecorubber-2 SKF Ecorubber-3 ² SKF Ecorubber-3 ² Back-up Ring SKF Ecopeak SKF Ecoflon 2 SKF Ecotal ¹ SKF Ecotal ¹ SKF Ecoflon 2 SKF Ecoflon 2 SKF Ecotal ¹	
S02-S 	Idraulica, tenuta stelo a singolo effetto <i>Hydraulic, single acting rod seal</i>	-30 +100 -20 +100 -20 +100 -40 +100	5 5 7 5	400 (5.800) 400 (5.800) 400 (5.800) 400 (5.800)	Tenuta Seal ECOPUR H-ECOPUR S-ECOPUR T-ECOPUR Back-up Ring SKF Ecotal ¹ SKF Ecotal ¹ SKF Ecotal ¹ SKF Ecotal ¹	
S03-P 	Idraulica, tenuta stelo a singolo effetto <i>Hydraulic, single acting rod seal</i>	-30 +100 -35 +110 -30 +100 -20 +100 -20 +100 -50 +110	0,5 0,5 0,5 0,5 0,7 0,5	400 (5.800) 400 (5.800) 400 (5.800) 400 (5.800) 400 (5.800) 400 (5.800)	Tenuta Seal ECOPUR ECOPUR LD G-ECOPUR H-ECOPUR S-ECOPUR T-ECOPUR O-Ring NBR 70 NBR 70 NBR 70 NBR 70 NBR 70 MVQ 70	
S03-F 	PTFE, tenuta stelo a singolo effetto <i>PTFE, single acting rod seal</i>	-55 +200 -30 +100 -50 +150 -20 +200 -55 +200 -30 +100 -55 +90 -30 +90	1 1 1 1 1 1 0,5 0,5	200 (2.900) 200 (2.900) 400 (5.800) 400 (5.800) 400 (5.800) 400 (5.800) 200 (2.900) 200 (2.900)	Tenuta Seal SKF Ecoflon 1 SKF Ecoflon 1 SKF Ecoflon 2,3,4 SKF Ecoflon 2,3,4 SKF Ecoflon 2,3,4 SKF Ecoflon 2,3,4 SKF Ecoflon 2,3,4 SKF Ecowear 1000 SKF Ecowear 1000 O-Ring MVQ 70 NBR 70 EPDM FPM 75 MVQ 70 NBR 70 MVQ 70 NBR 70	
S03-S 	PTFE, tenuta stelo a singolo effetto <i>PTFE, single acting rod seal</i>	-200 +260 -200 +260 -200 +90	1 1 0,5	200 (2.900) 400 (5.800) 200 (2.900)	Tenuta Seal SKF Ecoflon 1 SKF Ecoflon 2,3,4 SKF Ecowear 1000 Molla Spring 1.4310 1.4310 1.4310	

1. SKF Ecotal fino a Ø 260 mm, SKF Ecomid superiore a Ø 260 mm 1. SKF Ecotal up to Ø 260 mm, SKF Ecomid above Ø 260 mm







Tipo Type	Descrizione Description Usi Use	Condizioni di esercizio Operating conditions			Materiali Materials		
		T °C MIN / MAX	S m/s MAX	P bar (psi) MAX	Tenuta Seal	O-Ring	Tenuta Seal
S04-P 	Idrraulica, tenuta stelo a singolo effetto <i>Hydraulic, single acting rod seal</i>	-30 +100 -30 +100 -30 +100 -20 +100 -20 +100 -40 +100	0,5 0,5 0,5 0,5 0,7 0,5	700 (10.000) 700 (10.000) 700 (10.000) 700 (10.000) 700 (10.000) 700 (10.000)	ECOPUR ECOPUR LD G-ECOPUR H-ECOPUR S-ECOPUR T-ECOPUR	NBR 70 NBR 70 NBR 70 NBR 70 NBR 70 MVQ 70	SKF Ecotal ¹ SKF Ecomid SKF Ecomid SKF Ecotal ¹ SKF Ecotal ¹ SKF Ecotal ¹
S04-PD 	Idrraulica, tenuta stelo a singolo effetto <i>Hydraulic, single acting rod seal</i>	-30 +100 -30 +100 -30 +100 -20 +100 -20 +100 -40 +100	0,5 0,5 0,5 0,5 0,7 0,5	700 (10.000) 700 (10.000) 700 (10.000) 700 (10.000) 700 (10.000) 700 (10.000)	ECOPUR ECOPUR LD G-ECOPUR H-ECOPUR S-ECOPUR T-ECOPUR	NBR 70 NBR 70 NBR 70 NBR 70 NBR 70 MVQ 70	SKF Ecotal ¹ SKF Ecomid SKF Ecomid SKF Ecotal ¹ SKF Ecotal ¹ SKF Ecotal ¹
S05-P 	Pneumatica, tenuta stelo a singolo effetto <i>Pneumatic, single acting rod seal</i>	-30 +110 -35 +110 -30 +110 -20 +110 -20 +110 -50 +110	1 1 1 1 2 1	25 (360) 25 (360) 25 (360) 25 (360) 25 (360) 25 (360)	ECOPUR ECOPUR LD G-ECOPUR H-ECOPUR S-ECOPUR T-ECOPUR		
S05-R 	Pneumatica, tenuta stelo a singolo effetto <i>Pneumatic, single acting rod seal</i>	-10 +200 -25 +150 -30 +100 -20 +200 -50 +150	1 1 1 1 1	25 (360) 25 (360) 25 (360) 25 (360) 25 (360)	SKF Ecoflon SKF Ecorubber-H SKF Ecorubber-1 SKF Ecorubber-2 SKF Ecorubber-3 ¹		
S06-P 	Idrraulica, tenuta stelo a singolo effetto <i>Hydraulic, single acting rod seal</i>	-30 +110 -35 +110 -30 +110 -20 +110 -50 +110 -20 +110	0,5 0,5 0,5 0,5 0,5 0,7	400 (5.800) 400 (5.800) 400 (5.800) 400 (5.800) 400 (5.800) 400 (5.800)	ECOPUR ECOPUR LD G-ECOPUR H-ECOPUR S-ECOPUR T-ECOPUR		

1. SKF Ecotal fino a Ø 260 mm, SKF Ecomid superiore a Ø 260 mm
2. Non adatto per oli minerali
3. Raccomandato solo per applicazioni statiche o quasi statiche





1. SKF Ecotal up to Ø 260 mm, SKF Ecomid above Ø 260 mm
2. Not suitable for mineral oils
3. Only recommended for static or almost static applications



Tipo Type	Descrizione Description Usi Use	Condizioni di esercizio Operating conditions			Materiali Materials	
		T °C MIN / MAX	S m/s MAX	P bar (psi) MAX	Tenuta Seal	O-Ring
S06-R 	Idrraulica, tenuta stelo a singolo effetto <i>Hydraulic, single acting rod seal</i>	-10 +200 -25 +150 -30 +100 -20 +200 -50 +150 -60 +200	0,5 0,5 0,5 0,5 0,5 -	160 (2.300) 160 (2.300) 160 (2.300) 160 (2.300) 160 (2.300) -	SKF Ecoflon SKF Ecorubber-H SKF Ecorubber-1 SKF Ecorubber-2 SKF Ecorubber-3 ¹ SKF Ecosil ²	
S07-P 	Idrraulica, tenuta stelo a singolo effetto <i>Hydraulic, single acting rod seal</i>	-30 +100 -30 +100 -30 +100 -20 +100 -50 +110 -20 +100	0,5 0,5 0,5 0,5 0,5 0,7	400 (5.800) 400 (5.800) 400 (5.800) 400 (5.800) 400 (5.800) 400 (5.800)	ECOPUR ECOPUR LD G-ECOPUR H-ECOPUR T-ECOPUR S-ECOPUR	NBR 70 NBR 70 NBR 70 NBR 70 MVQ 70 NBR 70
S07-F 	PTFE, tenuta stelo a singolo effetto <i>PTFE, single acting rod seal</i>	-55 +200 -30 +100 -50 +150 -20 +200 -55 +200 -30 +100 -55 +90 -30 +90	1 1 1 1 1 1 0,5 0,5	200 (2.900) 200 (2.900) 400 (5.800) 400 (5.800) 400 (5.800) 400 (5.800) 200 (2.900) 200 (2.900)	SKF Ecoflon 1 SKF Ecoflon 1 SKF Ecoflon 2,3,4 SKF Ecoflon 2,3,4 SKF Ecoflon 2,3,4 SKF Ecoflon 2,3,4 SKF Ecowear 1000 SKF Ecowear 1000	MVQ 70 NBR 70 EPDM FPM 75 MVQ 70 NBR 70 MVQ 70 NBR 70
S08-P 	Idrraulica, tenuta stelo a singolo effetto <i>Hydraulic, single acting rod seal</i>	-30 +110 -20 +110 -20 +110 -50 +110	0,3 0,3 0,4 0,3	400 (5.800) 400 (5.800) 400 (5.800) 400 (5.800)	ECOPUR H-ECOPUR S-ECOPUR T-ECOPUR	
S08-PE 	Idrraulica, tenuta stelo a singolo effetto <i>Hydraulic, single acting rod seal</i>	-30 +110 -20 +110 -20 +110 -50 +110	0,3 0,3 0,4 0,3	400 (5.800) 400 (5.800) 400 (5.800) 400 (5.800)	ECOPUR H-ECOPUR S-ECOPUR T-ECOPUR	

1. SKF Ecotal fino a Ø 260 mm, SKF Ecomid superiore a Ø 260 mm 1. SKF Ecotal up to Ø 260 mm, SKF Ecomid above Ø 260 mm







Tipo Type	Descrizione Description Usi Use	Condizioni di esercizio Operating conditions			Materiali Materials
		T °C MIN / MAX	S m/s MAX	P bar (psi) MAX	
S08-R 	Idraulica, tenuta stelo a singolo effetto <i>Hydraulic, single acting rod seal</i>	-10 +200 -25 +150 -30 +100 -20 +200 -50 +150	0,3 0,3 0,3 0,3 0,3	160 (2.300) 160 (2.300) 160 (2.300) 160 (2.300) 160 (2.300)	Tenuta Seal SKF Ecoflas SKF Ecorubber-H SKF Ecorubber-1 SKF Ecorubber-2 SKF Ecorubber-3 ¹
S09-E 	Idraulica, tenuta stelo a singolo effetto <i>Hydraulic, single acting rod seal</i>	-55 +110 -30 +100 -55 +110 -30 +100 -20 +200 -30 +100 -55 +90 -30 +90	5 5 5 5 10 10 5 5	600 (8.700) 600 (8.700) 600 (8.700) 600 (8.700) 600 (8.700) 600 (8.700) 400 (5.800) 400 (5.800)	Pattino Glide Ring G-ECOPUR 54D G-ECOPUR 54D SKF ECOPUR, H, S SKF ECOPUR, H, S SKF Ecoflon 2,3,4 SKF Ecoflon 2,3,4 SKF Ecowear 1000 SKF Ecowear 1000 O-Ring MVQ 70 NBR 70 MVQ 70 NBR 70 FPM 75 NBR 70 MVQ 70 NBR 70
S09-D 	Idraulica, tenuta stelo a singolo effetto <i>Hydraulic, single acting rod seal</i>	-55 +110 -30 +100 -55 +110 -30 +100 -20 +200 -30 +100 -55 +90 -30 +90	5 5 5 5 10 10 5 5	600 (8.700) 600 (8.700) 600 (8.700) 600 (8.700) 600 (8.700) 600 (8.700) 400 (5.800) 400 (5.800)	Pattino Glide Ring G-ECOPUR 54D G-ECOPUR 54D SKF ECOPUR, H, S SKF ECOPUR, H, S SKF Ecoflon 2,3,4 SKF Ecoflon 2,3,4 SKF Ecowear 1000 SKF Ecowear 1000 O-Ring MVQ 70 NBR 70 MVQ 70 NBR 70 FPM 75 NBR 70 MVQ 70 NBR 70
S09-P 	Idraulica, tenuta stelo a singolo effetto <i>Hydraulic, single acting rod seal</i>	-30 +100 -30 +100 -30 +100 -20 +100 -20 +100 -50 +110	1 1 1 1 1,4 1	250 (3.600) 250 (3.600) 250 (3.600) 250 (3.600) 250 (3.600) 250 (3.600)	Pattino Glide Ring ECOPUR ECOPUR LD G-ECOPUR H-ECOPUR S-ECOPUR T-ECOPUR O-Ring NBR 70 NBR 70 NBR 70 NBR 70 NBR 70 MVQ 70
S09-ES 	Idraulica, tenuta stelo a singolo effetto <i>Hydraulic, single acting rod seal</i>	-30 +100 -60 +110 -30 +100 -60 +110 -30 +100 -20 +200 -30 +90 -60 +90	5 5 5 5 10 10 5 5	600 (8.700) 600 (8.700) 600 (8.700) 600 (8.700) 600 (8.700) 600 (8.700) 400 (5.800) 400 (5.800)	Pattino Glide Ring G-ECOPUR 54D G-ECOPUR 54D X-ECOPUR, H, S X-ECOPUR, H, S SKF Ecoflon 2,3,4 SKF Ecoflon 2,3,4 SKF Ecowear 1000 SKF Ecowear 1000 Energizzante Energizer SKF Ecorubber-1 SKF Ecosil SKF Ecorubber-1 SKF Ecosil SKF Ecorubber-1 SKF Ecorubber-2 SKF Ecorubber-1 SKF Ecosil

1. SKF Ecotal fino a Ø 260 mm, SKF Ecomid superiore a Ø 260 mm
2. Non adatto per oli minerali
3. Raccomandato solo per applicazioni statiche o quasi statiche

1. SKF Ecotal up to Ø 260 mm, SKF Ecomid above Ø 260 mm
2. Not suitable for mineral oils
3. Only recommended for static or almost static applications







Tipo Type	Descrizione Description Usi Use	Condizioni di esercizio Operating conditions			Materiali Materials
		T °C MIN / MAX	S m/s MAX	P bar (psi) MAX	
S09-DS 	Idraulica, tenuta stelo a doppio effetto <i>Hydraulic, double acting rod seal</i>	-30 +100 -60 +110 -30 +100 -60 +110 -30 +100 -20 +200 -30 +90 -60 +90	5 5 5 5 10 10 5 5	600 (8.700) 600 (8.700) 600 (8.700) 600 (8.700) 600 (8.700) 600 (8.700) 400 (5.800) 400 (5.800)	Pattino Glide Ring G-ECOPUR 54D G-ECOPUR 54D X-ECOPUR, H, S X-ECOPUR, H, S SKF Ecoflon 2,3,4 SKF Ecoflon 2,3,4 SKF Ecowear 1000 SKF Ecowear 1000 Energizzante Energizer SKF Ecorubber-1 SKF Ecosil SKF Ecorubber-1 SKF Ecosil SKF Ecorubber-1 SKF Ecorubber-2 SKF Ecorubber-1 SKF Ecosil
S1012-M 	Idraulica, tenuta pistone a singolo effetto <i>Hydraulic, single acting piston sea</i>	-30 +100 -35 +100 -30 +100 -20 +100 -20 +100 -25 +150 -30 +100 -20 +200 -50 +150	0,5 0,5 0,7 0,5 0,5 0,5 0,5 0,5 0,5	500 (7.200) 500 (7.200) 500 (7.200) 500 (7.200) 500 (7.200) 250 (3.600) 250 (3.600) 250 (3.600) 250 (3.600)	S 10-A SKF Ecotal ¹ SKF Ecomid SKF Ecomid SKF Ecotal ¹ SKF Ecotal ¹ SKF Ecoflon 2 SKF Ecoflon 2 SKF Ecoflon 2 SKF Ecoflon 2 S 11-T ECOPUR ECOPUR LD G-ECOPUR H-ECOPUR S-ECOPUR SKF Ecorubber-H SKF Ecorubber-1 SKF Ecorubber-2 SKF Ecorubber-3 S 12-T X-ECOPUR ³ SKF Ecomid G-ECOPUR 54D ⁴ X-ECOPUR H ³ X-ECOPUR S ³ SKF Ecoflon 2 SKF Ecoflon 2 SKF Ecoflon 2 SKF Ecoflon 2
S1012-T 	Idraulica, tenuta pistone a singolo effetto <i>Hydraulic, single acting piston sea</i>	-30 +100 -35 +100 -30 +100 -20 +100 -20 +100 -25 +150 -30 +100 -20 +200 -50 +150	0,5 0,5 0,7 0,5 0,5 0,5 0,5 0,5 0,5	500 (7.200) 500 (7.200) 500 (7.200) 500 (7.200) 500 (7.200) 250 (3.600) 250 (3.600) 250 (3.600) 250 (3.600)	S 10-A SKF Ecotal ¹ SKF Ecomid SKF Ecotal ¹ SKF Ecotal ¹ SKF Ecotal ¹ SKF Ecoflon 2 SKF Ecoflon 2 SKF Ecoflon 2 SKF Ecoflon 2 S 11-T ECOPUR ECOPUR LD G-ECOPUR H-ECOPUR S-ECOPUR SKF Ecorubber-H SKF Ecorubber-1 SKF Ecorubber-2 SKF Ecorubber-3 S 12-T X-ECOPUR ³ SKF Ecomid G-ECOPUR 54D ⁴ X-ECOPUR H ³ X-ECOPUR S ³ SKF Ecoflon 2 SKF Ecoflon 2 SKF Ecoflon 2 SKF Ecoflon 2
S1315-T 	Idraulica, tenuta pistone a singolo effetto <i>Hydraulic, single acting piston sea</i>	-30 +100 -35 +100 -30 +100 -30 +100 -20 +100 -20 +100 -20 +100 -20 +100 -20 +100 -40 +100	0,5 0,5 0,5 0,5 0,5 0,5 0,7 0,7 0,5	600 (8.700) 600 (8.700) 600 (8.700) 600 (8.700) 600 (8.700) 600 (8.700) 600 (8.700) 600 (8.700) 600 (8.700) 600 (8.700)	S 13-A SKF Ecotal ¹ SKF Ecotal ¹ SKF Ecomid SKF Ecomid SKF Ecotal ¹ SKF Ecotal ¹ SKF Ecotal ¹ SKF Ecotal ¹ SKF Ecotal ¹ SKF Ecotal ¹ S 14-T ECOPUR ECOPUR LD G-ECOPUR H-ECOPUR S-ECOPUR T-ECOPUR S 15-T X-ECOPUR SKF Ecotal ¹ SKF Ecomid SKF Ecomid X-ECOPUR H SKF Ecotal ¹ X-ECOPUR S SKF Ecotal ¹ SKF Ecotal ¹
S16-A 	Idraulica / pneumatica, tenuta cappello a singolo effetto <i>Hydraulic / pneumatic, single acting hat seal</i>	-30 +110 -35 +110 -30 +110 -20 +110 -20 +110 -50 +110 -10 +200 -25 +150 -30 +100 -20 +200 -50 +150	0,5 0,5 0,5 0,7 0,5 0,5 0,5 0,5 0,5 0,5 0,5	160 (2.300) 160 (2.300) 160 (2.300) 160 (2.300) 160 (2.300) 160 (2.300) 160 (2.300) 160 (2.300) 160 (2.300) 160 (2.300) 160 (2.300)	ECOPUR ECOPUR LD G-ECOPUR H-ECOPUR S-ECOPUR T-ECOPUR SKF ECOFLAS SKF ECORUBBER-H SKF ECORUBBER-1 SKF ECORUBBER-2 SKF ECORUBBER-3 ²

1. SKF Ecotal fino a Ø 260 mm, SKF Ecomid superiore a Ø 260 mm
2. Non adatto per oli minerali
3. SKF Ecotal alternativo fino a Ø 260 mm, SKF Ecomid sup. a Ø 260 mm
4. SKF Ecomid alternativo

1. SKF Ecotal up to Ø 260 mm, SKF Ecomid above Ø 260 mm
2. Not suitable for mineral oils
3. Alternative SKF Ecotal up to Ø 260 mm, SKF Ecomid above Ø 260 mm
4. SKF Ecomid alternativo







Tipo Type	Descrizione Description Usi Use	Condizioni di esercizio Operating conditions			Materiali Materials	
		T °C MIN / MAX	S m/s MAX	P bar (psi) MAX		
S16-B 	Idraulica/pneumatica, tenuta pistone a singolo effetto <i>Hydraulic/pneumatic, single acting piston seal</i>	-30 +110	0,5	160 (2.300)	Tenuta Seal ECOPUR	
		-35 +110	0,5	160 (2.300)	ECOPUR LD	
		-30 +110	0,5	160 (2.300)	G-ECOPUR	
		-20 +110	0,5	160 (2.300)	H-ECOPUR	
		-20 +110	0,7	160 (2.300)	S-ECOPUR	
		-50 +110	0,5	160 (2.300)	T-ECOPUR	
		-10 +200	0,5	160 (2.300)	SKF Ecoflas	
		-25 +150	0,5	160 (2.300)	SKF Ecorubber-H	
		-30 +100	0,5	160 (2.300)	SKF Ecorubber-1	
		-20 +200	0,5	160 (2.300)	SKF Ecorubber-2	
		-50 +150	0,5	160 (2.300)	SKF Ecorubber-3 ²	
S17-P 	Idraulica, tenuta stelo a singolo effetto <i>Hydraulic, single acting rod seal</i>	-30 +110	0,5	400 (5.800)	Tenuta Seal ECOPUR	
		-35 +110	0,5	400 (5.800)	ECOPUR LD	
		-30 +110	0,5	400 (5.800)	G-ECOPUR	
		-20 +110	0,5	400 (5.800)	H-ECOPUR	
		-20 +110	0,7	400 (5.800)	S-ECOPUR	
		-50 +110	0,5	400 (5.800)	T-ECOPUR	
S17-R 	Idraulica, tenuta stelo a singolo effetto <i>Hydraulic, single acting rod seal</i>	-10 +200	0,5	160 (2.300)	Tenuta Seal SKF Ecoflas	
		-25 +150	0,5	160 (2.300)	SKF Ecorubber-H	
		-30 +100	0,5	160 (2.300)	SKF Ecorubber-1	
		-20 +200	0,5	160 (2.300)	SKF Ecorubber-2	
		-50 +150	0,5	160 (2.300)	SKF Ecorubber-3 ²	
S18-P 	Idraulica, tenuta stelo a singolo effetto <i>Hydraulic, single acting rod seal</i>	-30 +100	0,5	600 (8.700)	Tenuta Seal ECOPUR	Back-up Ring SKF Ecotal ¹
		-35 +100	0,5	600 (8.700)	ECOPUR LD	SKF Ecomid
		-30 +100	0,5	600 (8.700)	G-ECOPUR	SKF Ecomid
		-20 +100	0,5	600 (8.700)	H-ECOPUR	SKF Ecotal ¹
		-20 +100	0,7	600 (8.700)	S-ECOPUR	SKF Ecotal ¹
		-20 +100	0,7	600 (8.700)	T-ECOPUR	SKF Ecotal ¹
		-40 +100	0,5	600 (8.700)		SKF Ecotal ¹
S18-R 	Idraulica, tenuta stelo a singolo effetto <i>Hydraulic, single acting rod seal</i>	-10 +200	0,5	250 (3.600)	Tenuta Seal SKF Ecoflas	Back-up Ring SKF Ecoflon 2
		-25 +150	0,5	250 (3.600)	SKF Ecorubber-H	SKF Ecoflon 2
		-25 +100	0,5	250 (3.600)	SKF Ecorubber-H	SKF Ecotal ¹
		-30 +100	0,5	250 (3.600)	SKF Ecorubber-1	SKF Ecotal ¹
		-20 +200	0,5	250 (3.600)	SKF Ecorubber-2	SKF Ecoflon 2
		-50 +150	0,5	250 (3.600)	SKF Ecorubber-3	SKF Ecoflon 2
		-40 +100	0,5	250 (3.600)	SKF Ecorubber-3	SKF Ecotal ¹

1. SKF Ecotal fino a Ø 260 mm, SKF Ecomid superiore a Ø 260 mm
2. Non adatto per oli minerali

1. SKF Ecotal up to Ø 260 mm, SKF Ecomid above Ø 260 mm
2. Not suitable for mineral oils







Tipo Type	Descrizione Description Usi Use	Condizioni di esercizio Operating conditions			Materiali Materials	
		T °C MIN / MAX	S m/s MAX	P bar (psi) MAX		
S19-F 	PTFE, tenuta stelo a singolo effetto <i>PTFE, single acting rod seal</i>	-200 +260	15	200 (2.900)	Pattino <i>Glide Ring</i> SKF Ecoflon 1	Molla <i>Spring</i> 1.4310 ³
		-200 +260	15	400 (5.800)	SKF Ecoflon 2	1.4310 ³
		-200 +260	15	400 (5.800)	SKF Ecoflon 3	1.4310 ³
		-200 +260	15	400 (5.800)	SKF Ecoflon 4	1.4310 ³
		-200 +90	15	200 (2.900)	SKF ECOWEAR 1000	1.4310 ³
S20-R 	Idraulica, tenuta stelo a doppio effetto <i>Hydraulic, double acting rod seal</i>	-25 +150	0,5	700 (10.000)	Tenuta Seal SKF Ecorubber-H	Back-up Ring SKF Ecoflon 2
		-25 +150	0,5	700 (10.000)	SKF Ecorubber-H	SKF Ecopeak
		-25 +100	0,5	700 (10.000)	SKF Ecorubber-H	SKF Ecotal ¹
		-30 +100	0,5	700 (10.000)	SKF Ecorubber-1	SKF Ecotal ¹
		-20 +200	0,5	700 (10.000)	SKF Ecorubber-2	SKF Ecoflon 2
		-20 +200	0,5	700 (10.000)	SKF Ecorubber-2	SKF Ecopeak
S21-P 	Idraulica, tenuta stelo a singolo effetto <i>Hydraulic, single acting rod seal</i>	-30 +100	0,5	400 (5.800)	Tenuta Seal ECOPUR	O-Ring NBR 70
		-20 +100	0,5	400 (5.800)	H-ECOPUR	NBR 70
		-20 +100	0,7	400 (5.800)	S-ECOPUR	NBR 70
		-50 +110	0,5	400 (5.800)	T-ECOPUR	MVQ 70
S22-P 	Idraulica, tenuta stelo a singolo effetto <i>Hydraulic, single acting rod seal</i>	-30 +100	0,5	400 (5.800)	Tenuta Seal ECOPUR	O-Ring SKF Ecotal ¹
		-35 +100	0,5	400 (5.800)	ECOPUR LD	SKF Ecomid
		-30 +100	0,5	400 (5.800)	G-ECOPUR	SKF Ecomid
		-20 +100	0,5	400 (5.800)	H-ECOPUR	SKF Ecotal ¹
		-20 +100	0,7	400 (5.800)	S-ECOPUR	SKF Ecotal ¹
		-20 +100	0,7	400 (5.800)	T-ECOPUR	SKF Ecotal ¹
		-40 +100	0,5	400 (5.800)		SKF Ecotal ¹
S22-R 	Idraulica, tenuta stelo a singolo effetto <i>Hydraulic, single acting rod seal</i>	-10 +200	0,5	160 (2.300)	Tenuta Seal SKF Ecoflas	O-Ring SKF Ecoflon
		-25 +150	0,5	160 (2.300)	SKF Ecorubber-H	SKF Ecoflon 2
		-25 +100	0,5	160 (2.300)	SKF Ecorubber-H	SKF Ecotal ¹
		-30 +100	0,5	160 (2.300)	SKF Ecorubber-1	SKF Ecotal ¹
		-20 +200	0,5	160 (2.300)	SKF Ecorubber-2	SKF Ecoflon 2
		-50 +150	0,5	160 (2.300)	SKF Ecorubber-3 ²	SKF Ecoflon 2
		-40 +100	0,5	160 (2.300)	SKF Ecorubber-3 ²	SKF Ecotal ¹

1. SKF Ecotal up to Ø 260 mm, SKF Ecomid superiore a Ø 260 mm
2. Non adatto per oli minerali
3. Specifica del materiale metallico della molla

1. SKF Ecotal up to Ø 260 mm, SKF Ecomid above Ø 260 mm
2. Not suitable for mineral oils
3. Spring metal material specification.

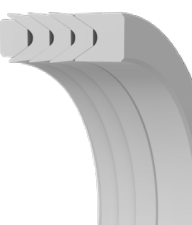



Tipo Type	Descrizione Description Usi Use	Condizioni di esercizio Operating conditions			Materiali Materials		
		T °C MIN / MAX	S m/s MAX	P bar (psi) MAX	Tenuta Seal	O-Ring	Back-up Ring
S24-P 	Idraulica, tenuta stelo a singolo effetto <i>Hydraulic, single acting rod seal</i>	-30 +100 -20 +100 -20 +100 -40 +100	0,5 0,5 0,7 0,5	700 (10.000) 700 (10.000) 700 (10.000) 700 (10.000)	ECOPUR H-ECOPUR S-ECOPUR T-ECOPUR	NBR 70 NBR 70 NBR 70 MVQ 70	SKF Ecotal ¹ SKF Ecotal ¹ SKF Ecotal ¹ SKF Ecotal ¹
S2527-F 	PTFE, tenuta stelo a singolo effetto <i>PTFE, single acting rod seal</i>	-200 +260	1,5	100 (1.450)	S25-F SKF Ecoflon 2	S26-F SKF Ecoflon 1	S27-F SKF Ecoflon 2
S2931-F 	PTFE, tenuta stelo a singolo effetto <i>PTFE, single acting rod seal</i>	-200 +260	1,5	315 (4.500)	S29-F SKF Ecoflon 2	S30-F SKF Ecoflon 1	S31-F SKF Ecoflon 2
S32-P 	Idraulica, tenuta stelo a singolo effetto <i>Hydraulic, single acting rod seal</i>	-30 +100 -30 +100 -35 +100 -30 +100 -30 +100 -20 +100 -20 +100 -20 +100 -20 +100 -40 +100	0,5 0,5 0,5 0,5 0,5 0,5 0,7 0,7 0,5	500 (7.200) 500 (7.200) 500 (7.200) 500 (7.200) 500 (7.200) 500 (7.200) 500 (7.200) 500 (7.200) 500 (7.200)	ECOPUR ECOPUR ECOPUR LD G-ECOPUR G-ECOPUR H-ECOPUR H-ECOPUR S-ECOPUR S-ECOPUR T-ECOPUR	Anello antiestrusione Pressure ring SKF Ecotal ¹ X-ECOPUR SKF Ecomid G-ECOPUR 54D SKF Ecomid X-ECOPUR H SKF Ecotal ¹ SKF Ecotal ¹ X-ECOPUR S SKF Ecotal ¹	Support Ring SKF Ecotal ¹ SKF Ecotal ¹ SKF Ecotal ¹ SKF Ecomid SKF Ecomid SKF Ecotal ¹ SKF Ecotal ¹ SKF Ecotal ¹ SKF Ecotal ¹ SKF Ecotal ¹
S35-P 	Idraulica, tenuta pistone a singolo effetto <i>Hydraulic, single acting rod seal</i>	-30 +110 -35 +110 -30 +110 -20 +110 -20 +110 -50 +110	0,4 0,4 0,4 0,4 0,5 0,4	400 (5.800) 400 (5.800) 400 (5.800) 400 (5.800) 400 (5.800) 400 (5.800)	ECOPUR ECOPUR LD G-ECOPUR H-ECOPUR S-ECOPUR T-ECOPUR		

1. SKF Ecotal fino a Ø 260 mm, SKF Ecomid superiore a Ø 260 mm
2. Non adatto per oli minerali

1. SKF Ecotal up to Ø 260 mm, SKF Ecomid above Ø 260 mm
2. Not suitable for mineral oils





Tipo Type	Descrizione Description Usi Use	Condizioni di esercizio Operating conditions			Materiali Materials
		T °C MIN / MAX	S m/s MAX	P bar (psi) MAX	
A01-A 	Idraulica, a singolo effetto <i>Hydraulic, single acting</i>	-30 +110 -35 +110 -30 +110 -30 +110 -20 +110 -20 +110 -50 +110 -30 +110 -20 +110 -20 +110 -10 +200 -25 +150 -30 +100 -20 +200 -50 +150	4 4 4 4 4 4 4 4 4 4 4 4 4 4 4	- - - - - - - - - - - - - - -	Tenuta Seal ECOPUR ECOPUR LD G-ECOPUR G-ECOPUR 54D ² H-ECOPUR S-ECOPUR T-ECOPUR X-ECOPUR ² X-ECOPUR H ² X-ECOPUR S ² SKF Ecoflas SKF Ecorubber-H SKF Ecorubber-1 SKF Ecorubber-2 SKF Ecorubber-3 ¹
A01-B 	Idraulica, a singolo effetto <i>Hydraulic, single acting</i>	-30 +110 -35 +110 -30 +110 -30 +110 -20 +110 -20 +110 -50 +110 -30 +110 -20 +110 -20 +110 -10 +200 -25 +150 -30 +100 -20 +200 -50 +150	4 4 4 4 4 4 4 4 4 4 4 4 4 4 4	- - - - - - - - - - - - - - -	Tenuta Seal ECOPUR ECOPUR LD G-ECOPUR G-ECOPUR 54D ² H-ECOPUR S-ECOPUR T-ECOPUR X-ECOPUR ² X-ECOPUR H ² X-ECOPUR S ² SKF Ecoflas SKF Ecorubber-H SKF Ecorubber-1 SKF Ecorubber-2 SKF Ecorubber-3 ¹
A02-A 	Idraulica, a singolo effetto <i>Hydraulic, single acting</i>	-30 +110 -35 +110 -30 +110 -30 +110 -20 +110 -20 +110 -50 +110 -30 +110 -20 +110 -20 +110 -10 +200 -25 +150 -30 +100 -20 +200 -50 +150	4 4 4 4 4 4 4 4 4 4 4 4 4 4 4	- - - - - - - - - - - - - - -	Tenuta Seal ECOPUR ECOPUR LD G-ECOPUR G-ECOPUR 54D ² H-ECOPUR S-ECOPUR T-ECOPUR X-ECOPUR ² X-ECOPUR H ² X-ECOPUR S ² SKF Ecoflas SKF Ecorubber-H SKF Ecorubber-1 SKF Ecorubber-2 SKF Ecorubber-3 ¹

1. Non adatto per oli minerali
2. Per poliuretani di elevata durezza, riferirsi alle proprietà dei materiali

1. Not suitable for mineral oils
2. For hard grade polyurethanes, refer to material properties





Tipo Type	Descrizione Description Usi Use	Condizioni di esercizio Operating conditions			Materiali Materials	
		T °C MIN / MAX	S m/s MAX	P bar (psi) MAX		
A02-B 	Idraulica, a singolo effetto <i>Hydraulic, single acting</i>	-30 +110	4	-	Tenuta Seal	
		-35 +110	4	-	ECOPUR	
		-30 +110	4	-	ECOPUR LD	
		-30 +110	4	-	G-ECOPUR	
		-30 +110	4	-	G-ECOPUR 54D ²	
		-20 +110	4	-	H-ECOPUR	
		-20 +110	4	-	S-ECOPUR	
		-50 +110	4	-	T-ECOPUR	
		-30 +110	4	-	X-ECOPUR ²	
		-20 +110	4	-	X-ECOPUR H ²	
		-20 +110	4	-	X-ECOPUR S ²	
		-10 +200	4	-	SKF Ecoflas	
		-25 +150	4	-	SKF Ecorubber-H	
		-30 +100	4	-	SKF Ecorubber-1	
-20 +200	4	-	SKF Ecorubber-2			
-50 +150	4	-	SKF Ecorubber-3 ¹			
A02-I 	Idraulica, a singolo effetto <i>Hydraulic, single acting</i>	-30 +110	4	-	Tenuta Seal	
		-20 +110	4	-	ECOPUR	
		-20 +110	4	-	H-ECOPUR	
		-50 +110	4	-	S-ECOPUR	
		-30 +110	4	-	T-ECOPUR	
		-30 +110	4	-	X-ECOPUR ²	
		-20 +110	4	-	X-ECOPUR H ²	
		-20 +110	4	-	X-ECOPUR S ²	
		-10 +200	4	-	SKF Ecoflas	
		-25 +150	4	-	SKF Ecorubber-H	
		-30 +100	4	-	SKF Ecorubber-1	
		-20 +200	4	-	SKF Ecorubber-2	
		-50 +150	4	-	SKF Ecorubber-3 ²	
		A03-A 	Idraulica, a singolo effetto <i>Hydraulic, single acting</i>	-30 +80	4	-
-20 +80	4			-	ECOPUR	SKF Ecotal ¹
-20 +80	5			-	H-ECOPUR	SKF Ecotal ¹
-40 +80	4			-	S-ECOPUR	SKF Ecotal ¹
-30 +80	4			-	T-ECOPUR	SKF Ecotal ¹
-30 +80	4			-	X-ECOPUR ²	SKF Ecotal ¹
-20 +80	4			-	X-ECOPUR H ²	SKF Ecotal ¹
-20 +80	5			-	X-ECOPUR S ²	SKF Ecotal ¹
-10 +200	4			-	SKF Ecoflas	SKF Ecopeak
-25 +80	4			-	SKF Ecorubber-H	SKF Ecotal ¹
-30 +80	4			-	SKF Ecorubber-1	SKF Ecotal ¹
-20 +200	4			-	SKF Ecorubber-2	SKF Ecopeak
-50 +150	4			-	SKF Ecorubber-3 ²	SKF Ecopeak

1. SKF Ecotal fino a Ø 260 mm, SKF Ecomid superiore a Ø 260 mm
 2. Non adatto per oli minerali
 3. Per poliuretani di elevata durezza, riferirsi alle proprietà dei materiali

1. SKF Ecotal up to Ø 260 mm, SKF Ecomid above Ø 260 mm
 2. Not suitable for mineral oils
 3. For hard grade polyurethanes, refer to material properties









Tipo Type	Descrizione Description Usi Use	Condizioni di esercizio Operating conditions			Materiali Materials
		T °C MIN / MAX	S m/s MAX	P bar (psi) MAX	
A04-A 	Pneumatica, a singolo effetto <i>Pneumatic, single acting</i>	-30 +110	4	-	Tenuta Seal
		-35 +110	4	-	ECOPUR
		-30 +110	4	-	ECOPUR LD
		-30 +110	4	-	G-ECOPUR
		-30 +110	4	-	G-ECOPUR 54D ³
		-20 +110	4	-	H-ECOPUR
		-20 +110	4	-	S-ECOPUR
		-50 +110	4	-	T-ECOPUR
		-30 +110	4	-	X-ECOPUR ²
		-20 +110	4	-	X-ECOPUR H ²
		-20 +110	4	-	X-ECOPUR S ²
		-10 +200	4	-	SKF Ecoflas
		-25 +150	4	-	SKF Ecorubber-H
		-30 +100	4	-	SKF Ecorubber-1
-20 +200	4	-	SKF Ecorubber-2		
-50 +150	4	-	SKF Ecorubber-3 ²		
A04-B 	Pneumatica, a singolo effetto <i>Pneumatic, single acting</i>	-30 +110	4	-	Tenuta Seal
		-35 +110	4	-	ECOPUR
		-30 +110	4	-	ECOPUR LD
		-30 +110	4	-	G-ECOPUR
		-30 +110	4	-	G-ECOPUR 54D ³
		-20 +110	4	-	H-ECOPUR
		-20 +110	4	-	S-ECOPUR
		-50 +110	4	-	T-ECOPUR
		-30 +110	4	-	X-ECOPUR ²
		-20 +110	4	-	X-ECOPUR H ²
		-20 +110	4	-	X-ECOPUR S ²
		-10 +200	4	-	SKF Ecoflas
		-25 +150	4	-	SKF Ecorubber-H
		-30 +100	4	-	SKF Ecorubber-1
-20 +200	4	-	SKF Ecorubber-2		
-50 +150	4	-	SKF Ecorubber-3 ²		
A05-A 	Pneumatica, a singolo effetto <i>Pneumatic, single acting</i>	-30 +110	4	-	Tenuta Seal
		-35 +110	4	-	ECOPUR
		-30 +110	4	-	ECOPUR LD
		-30 +110	4	-	G-ECOPUR
		-30 +110	4	-	G-ECOPUR 54D ³
		-20 +110	4	-	H-ECOPUR
		-20 +110	4	-	S-ECOPUR
		-50 +110	4	-	T-ECOPUR
		-30 +110	4	-	X-ECOPUR ²
		-20 +110	4	-	X-ECOPUR H ²
		-20 +110	4	-	X-ECOPUR S ²
		-10 +200	4	-	SKF Ecoflas
		-25 +150	4	-	SKF Ecorubber-H
		-30 +100	4	-	SKF Ecorubber-1
-20 +200	4	-	SKF Ecorubber-2		
-50 +150	4	-	SKF Ecorubber-3 ²		

1. Non adatto per oli minerali
 2. Per poliuretani di elevata durezza, riferirsi alle proprietà dei materiali

1. Not suitable for mineral oils
 2. For hard grade polyurethanes, refer to material properties









Tipo Type	Descrizione Description Usi Use	Condizioni di esercizio Operating conditions			Materiali Materials	
		T °C MIN / MAX	S m/s MAX	P bar (psi) MAX		
A05-B 	Pneumatica, a singolo effetto <i>Pneumatic, single acting</i>	-30 +110	4	-	Tenuta Seal	
		-20 +110	4	-	ECOPUR	
		-20 +110	4	-	H-ECOPUR	
		-50 +110	4	-	S-ECOPUR	
		-30 +110	4	-	T-ECOPUR	
		-20 +110	4	-	X-ECOPUR3	
		-20 +110	4	-	X-ECOPUR H ³	
		-20 +110	4	-	X-ECOPUR S ³	
		-10 +200	4	-	SKF Ecoflas	
		-25 +150	4	-	SKF Ecorubber-H	
		-30 +100	4	-	SKF Ecorubber-1	
		-20 +200	4	-	SKF Ecorubber-2	
-50 +150	4	-	SKF Ecorubber-3 ²			
						
A05-I 	Pneumatica, a singolo effetto <i>Pneumatic, single acting</i>	-30 +110	4	-	Tenuta Seal	
		-20 +110	4	-	ECOPUR	
		-20 +110	4	-	H-ECOPUR	
		-50 +110	4	-	S-ECOPUR	
		-30 +110	4	-	T-ECOPUR	
		-20 +110	4	-	X-ECOPUR3	
		-20 +110	4	-	X-ECOPUR H ³	
		-20 +110	4	-	X-ECOPUR S ³	
		-10 +200	4	-	SKF Ecoflas	
		-25 +150	4	-	SKF Ecorubber-H	
		-30 +100	4	-	SKF Ecorubber-1	
		-20 +200	4	-	SKF Ecorubber-2	
-50 +150	4	-	SKF Ecorubber-3 ²			
						
A06-A 	Pneumatica, a singolo effetto <i>Pneumatic, single acting</i>	-30 +80	4	-	Tenuta Seal	Sede Housing
		-20 +80	4	-	ECOPUR	SKF Ecotal ¹
		-20 +80	5	-	H-ECOPUR	SKF Ecotal ¹
		-40 +80	4	-	S-ECOPUR	SKF Ecotal ¹
		-30 +80	4	-	T-ECOPUR	SKF Ecotal ¹
		-30 +80	4	-	X-ECOPUR ³	SKF Ecotal ¹
		-20 +80	4	-	X-ECOPUR H ³	SKF Ecotal ¹
		-20 +80	5	-	X-ECOPUR S ³	SKF Ecotal ¹
		-10 +200	4	-	SKF Ecoflas	SKF Ecopeak
		-25 +80	4	-	SKF Ecorubber-H	SKF Ecotal ¹
		-30 +80	4	-	SKF Ecorubber-1	SKF Ecotal ¹
		-20 +200	4	-	SKF Ecorubber-2	SKF Ecopeak
-50 +150	4	-	SKF Ecorubber-3 ²	SKF Ecopeak		
						

1. SKF Ecotal fino a Ø 260 mm, SKF Ecomid superiore a Ø 260 mm
2. Non adatto per oli minerali
3. Per poliuretani di elevata durezza, riferirsi alle proprietà dei materiali

1. SKF Ecotal up to Ø 260 mm, SKF Ecomid above Ø 260 mm
2. Not suitable for mineral oils
3. For hard grade polyurethanes, refer to material properties





Tipo Type	Descrizione Description Usi Use	Condizioni di esercizio Operating conditions			Materiali Materials
		T °C MIN / MAX	S m/s MAX	P bar (psi) MAX	
A07-A 	Idraulica, a singolo effetto <i>Hydraulic, single acting</i>	-30 +110	4	-	Tenuta Seal
		-20 +110	4	-	ECOPUR
		-20 +110	4	-	H-ECOPUR
		-20 +110	4	-	S-ECOPUR
		-50 +110	4	-	T-ECOPUR
		-30 +110	4	-	X-ECOPUR3
		-20 +110	4	-	X-ECOPUR H ³
		-20 +110	5	-	X-ECOPUR S ³
		-10 +200	4	-	SKF Ecoflas
		-25 +150	4	-	SKF Ecorubber-H
		-30 +100	4	-	SKF Ecorubber-1
		-20 +200	4	-	SKF Ecorubber-2
-50 +150	4	-	SKF Ecorubber-3 ²		
					
A08-A 	Idraulica / pneumatica, a singolo effetto <i>Hydraulic / Pneumatic, single acting</i>	-30 +110	4	-	Tenuta Seal
		-35 +110	4	-	ECOPUR
		-30 +110	4	-	ECOPUR LD
		-30 +110	4	-	G-ECOPUR
		-30 +110	4	-	G-ECOPUR 54D ²
		-20 +110	4	-	H-ECOPUR
		-20 +110	4	-	S-ECOPUR
		-50 +110	4	-	T-ECOPUR
		-30 +110	4	-	X-ECOPUR ²
		-20 +110	4	-	X-ECOPUR H ²
		-20 +110	4	-	X-ECOPUR S ²
		-10 +200	4	-	SKF Ecoflas
-25 +150	4	-	SKF Ecorubber-H		
-30 +100	4	-	SKF Ecorubber-1		
-20 +200	4	-	SKF Ecorubber-2		
-50 +150	4	-	SKF Ecorubber-3 ¹		
					
A08-B 	Idraulica / pneumatica, a singolo effetto <i>Hydraulic / Pneumatic, single acting</i>	-30 +110	4	-	Tenuta Seal
		-35 +110	4	-	ECOPUR
		-30 +110	4	-	ECOPUR LD
		-30 +110	4	-	G-ECOPUR
		-30 +110	4	-	G-ECOPUR 54D ²
		-20 +110	4	-	H-ECOPUR
		-20 +110	4	-	S-ECOPUR
		-50 +110	4	-	T-ECOPUR
		-30 +110	4	-	X-ECOPUR ²
		-20 +110	4	-	X-ECOPUR H ²
		-20 +110	4	-	X-ECOPUR S ²
		-10 +200	4	-	SKF Ecoflas
-25 +150	4	-	SKF Ecorubber-H		
-30 +100	4	-	SKF Ecorubber-1		
-20 +200	4	-	SKF Ecorubber-2		
-50 +150	4	-	SKF Ecorubber-3 ¹		
					

1. SKF Ecotal fino a Ø 260 mm, SKF Ecomid superiore a Ø 260 mm
2. Non adatto per oli minerali
3. Per poliuretani di elevata durezza, riferirsi alle proprietà dei materiali

1. SKF Ecotal up to Ø 260 mm, SKF Ecomid above Ø 260 mm
2. Not suitable for mineral oils
3. For hard grade polyurethanes, refer to material properties



Tipo Type	Descrizione Description Usi Use	Condizioni di esercizio Operating conditions			Materiali Materials
		T °C MIN / MAX	S m/s MAX	P bar (psi) MAX	
A09-A 	Idraulica, a singolo effetto <i>Hydraulic, single acting</i>	-30 +110	4	-	Tenuta Seal ECOPUR H-ECOPUR S-ECOPUR T-ECOPUR X-ECOPUR ² X-ECOPUR H ² X-ECOPUR S ² SKF Ecoflas SKF Ecorubber-H SKF Ecorubber-1 SKF Ecorubber-2 SKF Ecorubber-3 ¹
		-20 +110	4	-	
		-20 +110	4	-	
		-50 +110	4	-	
		-30 +110	4	-	
		-20 +110	4	-	
		-20 +110	4	-	
		-10 +200	4	-	
		-25 +150	4	-	
		-30 +100	4	-	
		-20 +200	4	-	
		-50 +150	4	-	
		A10-A 	Idraulica, a singolo effetto <i>Hydraulic, single acting</i>	-30 +110	
-20 +110	4			-	
-20 +110	4			-	
-50 +110	4			-	
-30 +110	4			-	
-20 +110	4			-	
-20 +110	4			-	
-10 +200	4			-	
-25 +150	4			-	
-30 +100	4			-	
-20 +200	4			-	
-50 +150	4			-	
A11-A 	Idraulica / pneumatica, a singolo effetto <i>Hydraulic / Pneumatic, single acting</i>			-30 +110	4
		-35 +110	4	-	
		-30 +110	4	-	
		-20 +110	4	-	
		-20 +110	5	-	
		-50 +110	4	-	
		-10 +200	4	-	
		-25 +150	4	-	
		-30 +100	4	-	
		-20 +200	4	-	
		-50 +150	4	-	



1. Non adatto per oli minerali

2. Per poliuretani di elevata durezza, riferirsi alle proprietà dei materiali

1. Not suitable for mineral oils

2. For hard grade polyurethanes, refer to material properties







Tipo Type	Descrizione Description Usi Use	Condizioni di esercizio Operating conditions			Materiali Materials			
		T °C MIN / MAX	S m/s MAX	P bar (psi) MAX				
A11-I 	Idraulica / pneumatica, a doppio effetto <i>Hydraulic / Pneumatic, double acting</i>	-30 +110	4	-	Tenuta Seal ECOPUR H-ECOPUR T-ECOPUR S-ECOPUR SKF Ecoflas SKF Ecorubber-H SKF Ecorubber-1 SKF Ecorubber-2 SKF Ecorubber-3 ¹			
		-20 +110	4	-				
		-50 +110	4	-				
		-20 +110	5	-				
		-10 +200	4	-				
		-25 +150	4	-				
		-30 +100	4	-				
		-20 +200	4	-				
		-50 +150	4	-				
		A12-A 	Idraulica, a singolo effetto <i>Hydraulic, single acting</i>	-30 +110		4	-	Tenuta Seal ECOPUR LD G-ECOPUR G-ECOPUR 54D ² H-ECOPUR S-ECOPUR T-ECOPUR X-ECOPUR ² X-ECOPUR H ² X-ECOPUR S ²
				-35 +110		4	-	
				-30 +110		4	-	
				-20 +110		4	-	
-20 +110	5			-				
-50 +110	4			-				
-30 +110	4			-				
-20 +110	4			-				
-20 +110	5			-				
A12-B 	Idraulica, a doppio effetto <i>Hydraulic, double acting</i>			-30 +110	4	16 (230)	Tenuta Seal ECOPUR ECOPUR LD G-ECOPUR H-ECOPUR S-ECOPUR T-ECOPUR	
				-35 +110	4	16 (230)		
				-30 +110	4	16 (230)		
				-20 +110	4	16 (230)		
		-20 +110	5	16 (230)				
		-50 +110	4	16 (230)				

1. Non adatto per oli minerali

1. Not suitable for mineral oils







Tipo Type	Descrizione Description Usi Use	Condizioni di esercizio Operating conditions			Materiali Materials	
		T °C MIN / MAX	S m/s MAX	P bar (psi) MAX		
A13-A 	Idraulica / pneumatica, a singolo effetto <i>Hydraulic / pneumatic, single acting</i>	-70 +110	1	-	Tenuta Seal X-ECOPUR X-ECOPUR H X-ECOPUR S SKF Ecotal ¹ SKF Ecowear 1000 SKF Ecopeak	
		-70 +110	1	-		
		-70 +110	1	-		
		-50 +80	1	-		
		-200 +90	1	-		
		-100 +260	1	-		
A25-F 	Idraulica / pneumatica, a singolo effetto <i>Hydraulic / pneumatic, single acting</i>	-30 +110	5	-	Tenuta Seal X-ECOPUR X-ECOPUR H X-ECOPUR S SKF Ecoflon 2,3,4 SKF Ecoflon 2,3,4 SKF Ecowear 1000 SKF Ecowear 1000	Energizzante Energizer NBR 70 NBR 70 NBR 70 FPM 75 NBR 70 MVQ 70 NBR 70
		-20 +110	5	-		
		-20 +110	5	-		
		-20 +200	10	-		
		-30 +100	10	-		
		-55 +90	10	-		
		-30 +90	10	-		
A26-F 	Idraulica / pneumatica, a doppio effetto <i>Hydraulic / pneumatic, double acting</i>	-30 +100	5	16 (230)	Tenuta Seal G-ECOPUR 54D X-ECOPUR X-ECOPUR H X-ECOPUR S SKF Ecoflon 2,3,4 SKF Ecoflon 2,3,4 SKF Ecowear 1000 SKF Ecowear 1000	Energizzante Energizer NBR 70 NBR 70 NBR 70 NBR 70 FPM 75 NBR 70 MVQ 70 NBR 70
		-30 +100	5	16 (230)		
		-20 +100	5	16 (230)		
		-20 +100	5	16 (230)		
		-20 +200	10	16 (230)		
		-30 +100	10	16 (230)		
		-55 +90	10	16 (230)		
		-30 +90	10	16 (230)		
A27-F 	Idraulica / pneumatica, a doppio effetto <i>Hydraulic / pneumatic, double acting</i>	-30 +100	5	16 (230)	Tenuta Seal G-ECOPUR 54D X-ECOPUR X-ECOPUR H X-ECOPUR S SKF Ecoflon 2,3,4 SKF Ecoflon 2,3,4 SKF Ecowear 1000 SKF Ecowear 1000	Energizzante Energizer NBR 70 NBR 70 NBR 70 FPM 75 NBR 70 MVQ 70 NBR 70
		-30 +100	5	16 (230)		
		-20 +100	5	16 (230)		
		-20 +100	5	16 (230)		
		-20 +200	10	16 (230)		
		-30 +100	10	16 (230)		
		-55 +90	10	16 (230)		
		-30 +90	10	16 (230)		

1. SKF Ecotal fino a Ø 260 mm, SKF Ecomid superiore a Ø 260 mm

1. SKF Ecotal up to Ø 260 mm, SKF Ecomid above Ø 260 mm







Tipo Type	Descrizione Description Usi Use	Condizioni di esercizio Operating conditions			Materiali Materials
		T °C MIN / MAX	S m/s MAX	P bar (psi) MAX	
F01 	Anello guida, stelo/pistone <i>Guide ring, rod or piston application</i>	-200 +200	4	3	Tenuta Seal SKF Ecoflon 2 SKF Ecoflon 3 SKF Ecotal ¹ SKF Ecotex ²
		-200 +200	5	4.5	
		-50 +100	4	25	
		-40 +120	1	90	
F02 	Anello guida, stelo / pistone <i>Guide ring, rod or piston application</i>	-200 +200	4	3	Tenuta Seal SKF Ecoflon 2 SKF Ecoflon 3 SKF Ecotal ¹
		-200 +200	5	4.5	
		-50 +100	4	25	
F03 	Anello guida, applicazione pistone <i>Guide ring, piston application</i>	-200 +200	4	3	Tenuta Seal SKF Ecoflon 2 SKF Ecoflon 3 SKF Ecotal ¹
		-200 +200	5	4.5	
		-50 +100	4	25	
F04 	Anello guida, applicazione stelo <i>Guide ring, rod application</i>	-200 +200	4	3	Tenuta Seal SKF Ecoflon 2 SKF Ecoflon 3 SKF Ecotal ¹
		-200 +200	5	4.5	
		-50 +100	4	25	

1. SKF Ecotal fino a Ø 260 mm, SKF Ecomid superiore a Ø 260 mm
2. Tessuto rinforzato in resina poliesteri, disponibile solo come nastro guida

1. SKF Ecotal up to Ø 260 mm, SKF Ecomid above Ø 260 mm
2. Special fabric reinforced material, available as a guide tape only





Tipo Type	Descrizione Description Uso Use	Condizioni di esercizio Operating conditions			Materiali Materials
		T °C MIN / MAX	S m/s MAX	P bar (psi) MAX	
F05 	Anello guida, applicazione pistone <i>Guide ring, piston application</i>	-200 +200 -200 +200 -50 +100	4 5 4	3 4.5 25	Tenuta Seal SKF Ecoflon 2 SKF Ecoflon 3 SKF Ecotal ¹
F06 	Anello guida, applicazione stelo <i>Guide ring, rod application</i>	-200 +200 -200 +200 -50 +100	4 5 4	3 4.5 25	Tenuta Seal SKF Ecoflon 2 SKF Ecoflon 3 SKF Ecotal ¹
F07 	Anello guida, applicazione pistone <i>Guide ring, piston application</i>	-200 +200 -200 +200 -50 +100	4 5 4	3 4.5 25	Tenuta Seal SKF Ecoflon 2 SKF Ecoflon 3 SKF Ecotal ¹
F08 	Anello guida, applicazione stelo <i>Guide ring, rod application</i>	-200 +200 -200 +200 -50 +100	4 5 4	3 4.5 25	Tenuta Seal SKF Ecoflon 2 SKF Ecoflon 3 SKF Ecotal ¹

1. SKF Ecotal fino a Ø 260 mm, SKF Ecomid superiore a Ø 260 mm
2. Soggetto a temperatura e a compressione consentita

1. SKF Ecotal up to Ø 260 mm, SKF Ecomid above Ø 260 mm
2. Depending on temperature and allowable compression



Tipo Type	Descrizione Description Uso Use	Condizioni di esercizio Operating conditions			Materiali Materials
		T °C MIN / MAX	S m/s MAX	P bar (psi) MAX	
ST08 	Back-up ring, inattivo e utilizzato con O-Ring <i>Back-up ring, inactive and used with O-Ring</i>	-70 +110 -70 +110 -70 +110 -70 +110 -70 +110 -70 +110 -70 +110 -70 +110 -70 +110 -70 +110 -200 +260 -200 +260 -40 +100 -100 +260 -50 +100	- - - - - - - - - - - - - - -	- - - - - - - - - - - - - - -	Tenuta Seal ECOPUR ECOPUR LD G-ECOPUR G-ECOPUR 54D H-ECOPUR S-ECOPUR T-ECOPUR X-ECOPUR X-ECOPUR H X-ECOPUR S SKF Ecoflon 1 SKF Ecoflon 2 SKF Ecomid ² SKF Ecopaek SKF Ecotal ¹
ST09 	Back-up ring, inattivo per O-Ring <i>Back-up ring, inactive for O-Ring</i>	-70 +110 -70 +110 -70 +110 -70 +110 -70 +110 -70 +110 -70 +110 -70 +110 -70 +110 -70 +110 -200 +260 -200 +260 -40 +100 -100 +260 -50 +100	- - - - - - - - - - - - - - -	- - - - - - - - - - - - - - -	Tenuta Seal ECOPUR ECOPUR LD G-ECOPUR G-ECOPUR 54D H-ECOPUR S-ECOPUR T-ECOPUR X-ECOPUR X-ECOPUR H X-ECOPUR S SKF Ecoflon 1 SKF Ecoflon 2 SKF Ecomid ² SKF Ecopaek SKF Ecotal ¹
ST10 	Back-up ring, attivo e utilizzato per pistoni di tipo PD <i>Back-up ring, active for piston seal type PD</i>	-200 +260 -40 +100 -100 +260 -50 +100	- - - -	- - - -	Tenuta Seal SKF Ecoflon 2 SKF Ecomid ² SKF Ecopaek SKF Ecotal ¹

1. Fino a Ø 260 mm
2. Superiore a Ø 260 mm

1. Up to Ø 260 mm
2. Above Ø 260 mm



Tipo Type	Descrizione Description Usò Use	Condizioni di esercizio Operating conditions			Materiali Materials
		T °C MIN / MAX	S m/s MAX	P bar (psi) MAX	
ST11	Back-up ring, attivo e utilizzato per stelo di tipo PD <i>Back-up ring, active for rod seal type PD</i>	-200 +260 -40 +100 -100 +260 -50 +100	- - - -	- - - -	Tenuta Seal SKF Ecoflon 2 SKF Ecomid ² SKF Ecopaek SKF Ecotal ¹
ST12	Back-up ring, triangolare per applicazione stelo per sedi speciali <i>Back-up ring, triangular for rod application which fits in special housings</i>	-200 +260 -40 +100 -100 +260 -50 +100	- - - -	- - - -	Tenuta Seal SKF Ecoflon 2 SKF Ecomid ² SKF Ecopaek SKF Ecotal ¹
ST13	Back-up ring, triangolare per applicazione pistone per sedi speciali <i>Back-up ring, triangular for piston application which fits in special housings</i>	-200 +260 -40 +100 -100 +260 -50 +100	- - - -	- - - -	Tenuta Seal SKF Ecoflon 2 SKF Ecomid ² SKF Ecopaek SKF Ecotal ¹

1. Fino a Ø 260 mm
2. Superiore a Ø 260 mm

1. Up to Ø 260 mm
2. Above Ø 260 mm







Tipo Type	Descrizione Description Usò Use	Condizioni di esercizio Operating conditions			Materiali Materials	
		T °C MIN / MAX	S m/s MAX	P bar (psi) MAX	Tenuta Seal	Energizzante Energizer
R01-P	Tenuta per albero rotante singolo effetto <i>Single acting rotary shaft seal</i>	-30 +80 -35 +80 -30 +80 -20 +80 -20 +80 -40 +80	5 ³ 5 ³ 5 ³ 5 ³ 5 ³ 5 ³	0,5 (7) 0,5 (7) 0,5 (7) 0,5 (7) 0,5 (7) 0,5 (7)	ECOPUR ECOPUR LD G-ECOPUR H-ECOPUR S-ECOPUR T-ECOPUR	SKF Ecotal ¹ SKF Ecomid SKF Ecomid SKF Ecotal ¹ SKF Ecotal ¹ SKF Ecotal ¹
R01-R	Tenuta per albero rotante singolo effetto <i>Single acting rotary shaft seal</i>	-10 +200 -25 +80 -30 +80 -20 +200 -50 +80 -50 +150 -50 +80 -60 +200	10 ⁵ 10 ⁵ 10 ⁵ 15 ³ 10 ⁵ 10 ⁵ 5 ³ 5 ³	0,5 (7) 0,5 (7) 0,5 (7) 0,5 (7) 0,5 (7) 0,5 (7) 0,2 (3) 0,2 (3)	SKF Ecoflon 2 SKF Ecorubber-H SKF Ecorubber-1 SKF Ecorubber-2 SKF Ecorubber-3 ² SKF Ecorubber-3 ² SKF Ecosil SKF Ecosil	Metal SKF Ecotal ¹ SKF Ecotal ¹ Metal SKF Ecotal ¹ Metal SKF Ecotal ¹ Metal
R01-AF	Tenuta per albero rotante singolo effetto <i>Single acting rotary shaft seal</i>	-30 +110 -35 +110 -30 +110 -20 +110 -20 +110 -50 +110 -10 +200 -25 +150 -30 +100 -20 +200 -50 +150 -60 +200	5 ³ 5 ³ 5 ³ 5 ³ 5 ³ 5 ³ 10 ⁵ 10 ⁵ 10 ⁵ 15 ³ 10 ⁵ 5 ³	0,5 (7) 0,5 (7) 0,5 (7) 0,5 (7) 0,5 (7) 0,5 (7) 0,5 (7) 0,5 (7) 0,5 (7) 0,5 (7) 0,2 (3) 0,2 (3)	ECOPUR ECOPUR LD G-ECOPUR H-ECOPUR S-ECOPUR T-ECOPUR SKF Ecoflon 2 SKF Ecorubber-H SKF Ecorubber-1 SKF Ecorubber-2 SKF Ecorubber-3 ² SKF Ecosil	
R01-AS	Tenuta per albero rotante singolo effetto <i>Single acting rotary shaft seal</i>	-30 +110 -35 +110 -30 +110 -20 +110 -20 +110 -50 +110 -10 +200 -25 +150 -30 +100 -20 +200 -50 +150 -60 +200	5 ³ 5 ³ 5 ³ 5 ³ 5 ³ 5 ³ 10 ⁵ 10 ⁵ 10 ⁵ 15 ³ 10 ⁵ 5 ³	0,5 (7) 0,5 (7) 0,5 (7) 0,5 (7) 0,5 (7) 0,5 (7) 0,5 (7) 0,5 (7) 0,5 (7) 0,5 (7) 0,2 (3) 0,2 (3)	ECOPUR ECOPUR LD G-ECOPUR H-ECOPUR S-ECOPUR T-ECOPUR SKF Ecoflon 2 SKF Ecorubber-H SKF Ecorubber-1 SKF Ecorubber-2 SKF Ecorubber-3 ² SKF Ecosil	

1. SKF Ecotal fino a Ø 260 mm, SKF Ecomid superiore a Ø 260 mm
2. Tessuto rinforzato in resina poliestere, disponibile solo come nastro guida
3. I valori di limite di velocità superficiale sono basati sulla capacità di dissipazione del calore del sistema di tenuta (diametro dell'albero, lubrificazione...)

1. SKF Ecotal up to Ø 260 mm, SKF Ecomid above Ø 260 mm
2. Special fabric reinforced material, available as a guide tape only
3. Surface speed limit values are depending on heat dissipation ability of the sealing system (shaft diameter, lubrication...)







Tipo Type	Descrizione Description Usò Use	Condizioni di esercizio Operating conditions			Materiali Materials	
		T °C MIN / MAX	S m/s MAX	P bar (psi) MAX	Tenuta Seal	O-Ring
R01-F 	Tenuta per albero rotante singolo effetto. PTFE caricato guarnizione a labbro <i>Single acting rotary shaft seal. Spring loaded PTFE lip seal</i>	-20 +200 -30 +100	10 ³ 10 ³	15 (210) 15 (210)	SKF Ecoflon 4 SKF Ecoflon 4	FPM 75 NBR 70
R02-P 	Tenuta per albero rotante singolo effetto con labbro antipolvere <i>Single acting rotary shaft seal with additional dust lip</i>	-30 +80 -35 +80 -30 +80 -20 +80 -20 +80 -40 +80	5 ³ 5 ³ 5 ³ 5 ³ 5 ³ 5 ³	0,5 (7) 0,5 (7) 0,5 (7) 0,5 (7) 0,5 (7) 0,5 (7)	ECOPUR ECOPUR LD G-ECOPUR H-ECOPUR S-ECOPUR T-ECOPUR	SKF Ecotal ¹ SKF Ecomid SKF Ecomid SKF Ecotal ¹ SKF Ecotal ¹ SKF Ecotal ¹
R02-R 	Tenuta per albero rotante singolo effetto con labbro antipolvere <i>Single acting rotary shaft seal with additional dust lip</i>	-10 +200 -25 +80 -30 +80 -20 +200 -50 +80 -50 +150 -50 +80 -60 +200	10 ³ 10 ³ 10 ³ 15 ³ 10 ³ 10 ³ 5 ³ 5 ³	0,5 (7) 0,5 (7) 0,5 (7) 0,5 (7) 0,5 (7) 0,5 (7) 0,2 (3) 0,2 (3)	SKF Ecoflas SKF Ecorubber-H SKF Ecorubber-1 SKF Ecorubber-2 SKF Ecorubber-3 ² SKF Ecorubber-3 ² SKF Ecosil SKF Ecosil	Metal SKF Ecotal ¹ SKF Ecotal ¹ Metal SKF Ecotal ¹ Metal SKF Ecotal ¹ Metal
R03-P 	Tenuta per albero rotante doppio effetto con anelli di backup <i>Double acting rotary seal with integrated backup rings</i>	-30 +100 -20 +100 -20 +100 -40 +100	0,2 0,2 0,3 0,2	400 (5.800) 400 (5.800) 400 (5.800) 400 (5.800)	ECOPUR H-ECOPUR S-ECOPUR T-ECOPUR	SKF Ecotal ¹ SKF Ecotal ¹ SKF Ecotal ¹ SKF Ecotal ¹

1. SKF Ecotal fino a Ø 260 mm, SKF Ecomid superiore a Ø 260 mm
2. Tessuto rinforzato in resina poliestere, disponibile solo come nastro guida
3. I valori di limite di velocità superficiale sono basati sulla capacità di dissipazione del calore del sistema di tenuta (diametro dell'albero, lubrificazione...)





1. SKF Ecotal up to Ø 260 mm, SKF Ecomid above Ø 260 mm
2. Special fabric reinforced material, available as a guide tape only
3. Surface speed limit values are depending on heat dissipation ability of the sealing system (shaft diameter, lubrication...)



Tipo Type	Descrizione Description Usò Use	Condizioni di esercizio Operating conditions			Materiali Materials	
		T °C MIN / MAX	S m/s MAX	P bar (psi) MAX	Tenuta Seal	O-Ring
R03-R 	Tenuta per rotativa a doppio effetto <i>Double acting rotary seal</i>	-10 +200 -25 +100 -30 +100 -20 +200 -50 +150 -40 +100	0,2 0,2 0,2 0,2 0,2 0,2	250 (3.600) 250 (3.600) 250 (3.600) 250 (3.600) 250 (3.600) 250 (3.600)	SKF Ecoflas SKF Ecorubber-H SKF Ecorubber-1 SKF Ecorubber-2 SKF Ecorubber-3 SKF Ecorubber-3	SKF Ecopaek SKF Ecotal ¹ SKF Ecotal ¹ SKF Ecoflon 2 SKF Ecoflon 2 SKF Ecotal ¹
R04-A 	Tenuta per rotativa a doppio effetto <i>Double acting rotary seal</i>	-30 +110 -20 +110 -20 +110 -50 +110 -10 +200 -25 +150 -30 +100 -20 +200 -50 +150	0,2 0,2 0,3 0,2 0,2 0,2 0,2 0,2 0,2	160 (2.300) 160 (2.300) 160 (2.300) 160 (2.300) 100 (1.450) 100 (1.450) 100 (1.450) 100 (1.450) 100 (1.450)	ECOPUR H-ECOPUR S-ECOPUR T-ECOPUR SKF Ecoflas SKF Ecorubber-H SKF Ecorubber-1 SKF Ecorubber-2 SKF Ecorubber-3 ²	
R05-A 	Idraulica, tenuta per rotativa a doppio effetto <i>Hydraulic, double acting rotary seal</i>	-30 +110 -20 +110 -20 +110 -50 +110 -10 +200 -25 +150 -30 +100 -20 +200 -50 +150	0,2 0,2 0,3 0,2 0,2 0,2 0,2 0,2 0,2	160 (2.300) 160 (2.300) 160 (2.300) 160 (2.300) 100 (1.450) 100 (1.450) 100 (1.450) 100 (1.450) 100 (1.450)	ECOPUR H-ECOPUR S-ECOPUR T-ECOPUR SKF Ecoflas SKF Ecorubber-H SKF Ecorubber-1 SKF Ecorubber-2 SKF Ecorubber-3 ²	
R06-P 	Tenuta rotante ad azione assiale <i>Axially acting rotary seal</i>	-30 +110 -35 +110 -30 +110 -20 +110 -20 +110 -50 +110	25 25 25 25 25 25	- - - - - -	ECOPUR ECOPUR LD G-ECOPUR H-ECOPUR S-ECOPUR T-ECOPUR	

1. Tessuto rinforzato in resina poliestere, disponibile solo come nastro guida
2. I valori di limite di velocità superficiale sono basati sulla capacità di dissipazione del calore del sistema di tenuta (diametro dell'albero, lubrificazione...)
1. Special fabric reinforced material, available as a guide tape only
2. Surface speed limit values are depending on heat dissipation ability of the sealing system (shaft diameter, lubrication...)







Tipo Type	Descrizione Description Uso Use	Condizioni di esercizio Operating conditions			Materiali Materials
		T °C MIN / MAX	S m/s MAX	P bar (psi) MAX	
R06-R 	Tenuta rotante ad azione assiale <i>Axially acting rotary seal</i>	-10 +200 -25 +150 -30 +100 -20 +200 -50 +150	25 25 25 25 25	- - - - -	Tenuta Seal SKF Ecoflas SKF Ecorubber-H SKF Ecorubber-1 SKF Ecorubber-2 SKF Ecorubber-3 ¹
R07-P 	Tenuta rotante ad azione assiale <i>Axially acting rotary seal</i>	-30 +110 -35 +110 -30 +110 -20 +110 -20 +110 -50 +110	25 25 25 25 25 25	- - - - - -	Tenuta Seal ECOPUR ECOPUR LD G-ECOPUR H-ECOPUR S-ECOPUR T-ECOPUR
R07-R 	Tenuta rotante ad azione assiale <i>Axially acting rotary seal</i>	-10 +200 -25 +150 -30 +100 -20 +200 -50 +150	25 25 25 25 25	- - - - -	Tenuta Seal SKF Ecoflas SKF Ecorubber-H SKF Ecorubber-1 SKF Ecorubber-2 SKF Ecorubber-3 ¹
R08-A 	Tenuta per singolo effetto <i>Single acting rotary seal</i>	-30 +110 -35 +110 -30 +110 -20 +110 -20 +110 -50 +100 30 +100 25 +150 20 +200 50 +150 10 +200 60 +200	- - - - - - - - - - - -	- - - - - - - - - - - -	Tenuta Seal ECOPUR ECOPUR LD G-ECOPUR H-ECOPUR S-ECOPUR T-ECOPUR SKF Ecorubber-1 SKF Ecorubber-H SKF Ecorubber-2 SKF Ecorubber-3 ¹ SKF Ecoflas SKF Ecosil









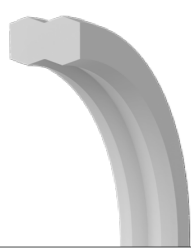

1. Non adatto per oli minerali

1. Not suitable for mineral oils

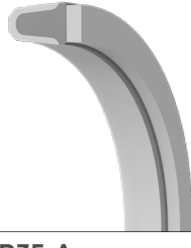

Tipo Type	Descrizione Description Uso Use	Condizioni di esercizio Operating conditions			Materiali Materials	
		T °C MIN / MAX	S m/s MAX	P bar (psi) MAX		
R09-F 	Tenuta rotativa a doppio effetto <i>Double-acting rotary seal</i>	-20 +200 -30 +100	0,4 0,4	350 (5.000) 350 (5.000)	Pattino <i>Glide Ring</i> SKF Ecoflon 4 SKF Ecoflon 4	Energizzante <i>Energizer</i> FPM 75 NBR 70
R09-FS 	Tenuta rotativa a doppio effetto <i>Double-acting rotary seal</i>	-30 +100 -20 +200	0,4 0,4	350 (5.000) 350 (5.000)	Pattino <i>Glide Ring</i> SKF Ecoflon 4 SKF Ecoflon 4	Energizzante <i>Energizer</i> SKF Ecorubber-1 SKF Ecorubber-2
R10-F 	Tenuta rotativa a doppio effetto <i>Double-acting rotary seal</i>	-20 +200 -30 +100	0,4 0,4	350 (5.000) 350 (5.000)	Pattino <i>Glide Ring</i> SKF Ecoflon 4 SKF Ecoflon 4	Energizzante <i>Energizer</i> FPM 75 NBR 70
R10-FS 	Tenuta rotativa a doppio effetto <i>Double-acting rotary seal</i>	-30 +100 -20 +200	0,4 0,4	350 (5.000) 350 (5.000)	Tenuta Seal SKF Ecoflon 4 SKF Ecoflon 4	Energizzante <i>Energizer</i> SKF Ecorubber-1 SKF Ecorubber-2



Tipo Type	Descrizione Description Usò Use	Condizioni di esercizio Operating conditions			Materiali Materials		
		T °C MIN / MAX	S m/s MAX	P bar (psi) MAX			
R15-P 	Tenuta statica a doppio effetto <i>Double-acting static seal</i> 	-30 +110	-	400 (5.800)	ECOPUR		
		-35 +110	-	400 (5.800)	ECOPUR LD		
		-30 +110	-	400 (5.800)	G-ECOPUR		
		-20 +110	-	400 (5.800)	H-ECOPUR		
		-20 +110	-	400 (5.800)	S-ECOPUR		
		-50 +110	-	400 (5.800)	T-ECOPUR		
R16 	Tenuta statica a doppio effetto <i>Double-acting static seal</i> 	-10 +200	-	50 (3.600)	SKF Ecoflas		
		-25 +150	-	50 (3.600)	SKF Ecorubber-H		
		-30 +110	-	50 (3.600)	SKF Ecorubber-1		
		-20 +200	-	50 (3.600)	SKF Ecorubber-2		
		-50 +150	-	50 (3.600)	SKF Ecorubber-3 ¹		
R20-P 	Tenuta a flangia a singolo effetto <i>Single-acting flange seal</i> 	-30 +110	-	800 (11.600)	ECOPUR		
		-35 +110	-	800 (11.600)	ECOPUR LD		
		-30 +110	-	800 (11.600)	G-ECOPUR		
		-20 +110	-	800 (11.600)	H-ECOPUR		
		-20 +110	-	800 (11.600)	S-ECOPUR		
		-50 +110	-	800 (11.600)	T-ECOPUR		
R30-A 	Tenuta valvola stelo con rivestimento in PTFE <i>Valve stem seal with PTFE jacket</i> 	-25 +200	0,5	1000 (14.500)	SKF Ecorubber-H	Rivestimento Cover	Back-up Ring
		-25 +100	0,5	500 (7.200)	SKF Ecorubber-H	SKF Ecoflon ²	SKF Ecopaek
		-20 +200	0,5	1000 (14.500)	SKF Ecorubber-2	SKF Ecoflon ²	SKF Ecotal ³
		-20 +100	0,5	500 (7.200)	SKF Ecorubber-2	SKF Ecoflon ²	SKF Ecopaek
R35-A 	Tenuta a flangia a singolo effetto <i>Single-acting flange seal</i> 	-30 +110	-	800 (11.600)	ECOPUR		
		-35 +110	-	800 (11.600)	ECOPUR LD		
		-30 +110	-	800 (11.600)	G-ECOPUR		
		-20 +110	-	800 (11.600)	H-ECOPUR		
		-20 +110	-	800 (11.600)	S-ECOPUR		
		-50 +110	-	800 (11.600)	T-ECOPUR		
		-10 +200	-	250 (3.600)	SKF Ecoflas		
		-25 +150	-	250 (3.600)	SKF Ecorubber-H		
		-30 +100	-	250 (3.600)	SKF Ecorubber-1		
		-20 +200	-	250 (3.600)	SKF Ecorubber-2		
		-50 +150	-	250 (3.600)	SKF Ecorubber-3 ¹		
		-60 +200	-	250 (3.600)	SKF Ecosil		

1. Non adatto per oli minerali

2. Per tutti i tipi di SKF Ecoflon, fare riferimento alle proprietà del materiale

3. SKF Ecotal fino a Ø 260 mm, SKF Ecomid superiore a Ø 260 mm

1. Not suitable for mineral oils

2. For all types of SKF Ecoflon, refer to material properties

3. SKF Ecotal up to Ø 260 mm, SKF Ecomid above Ø 260 mm



FRIDLE

VICENZA

Via G. Galilei, 53 - 36030 Costabissara (VI) - Italy
T. +39 0444 971856 - info@fridle.com

BRESCIA

Via A. Maestri, 14 - 25125 Brescia (BS) - Italy
T. +39 030 6700301 - fridleBS@fridle.com

MANTOVA

Via Sabin, 12/a - 46029 Suzzara (MN) - Italy
T. +39 0376 274885 - fridleMN@fridle.com

MODENA

Via del Crociale, 34 - 41042 Fiorano Modenese (MO) - Italy
T. +39 0536 1795600 - fridleMO@fridle.com

Richieste d'offerta: richieste@fridle.com
Requests for quotation: enquiries@fridle.com
Ordini: ordini@fridle.com
Orders: orders@fridle.com

GUARNIFLUID

Via Nino Bixio, 28 - 10048 Vinovo (TO) - Italy
T. +39 011 317 0052 - info@guarnifluid.it
guarnifluid.com

HT

Via Galvani, 10 - 36010 Zanè (VI) - Italy
T.+39 0445 540632 - info@ht-hydraulic.com
ht-hydraulic.com

FRIDLE ACADEMY

Via G. Galilei, 53 - 36030 Costabissara (VI) - Italy
T. +39 0444 971856
Segreteria didattica - frg.academy@fridle.com



fridle.com

Le indicazioni tecniche riportate in questo documento vengono fornite a Fridle Group S.r.l. dai partner, hanno carattere indicativo e non costituiscono istruzioni d'uso. Fridle Group S.r.l. declina ogni responsabilità per il loro contenuto.

The technical specifications contained in this document are provided to Fridle Group S.r.l. by the partners, it is to be considered indicative and it does not constitute instructions for use. Fridle Group S.r.l. declines any responsibility for its content.